

SFI SYSTEM

PRECAUTION

SF05M-04

1. BEFORE WORKING ON FUEL SYSTEM, DISCONNECT NEGATIVE (-) TERMINAL CABLE FROM BATTERY

HINT:

Any diagnostic trouble code retained by the computer will be erased when the negative (-) terminal cable is removed from the battery.

Therefore, if necessary, read the diagnosis before removing the negative (-) terminal cable from the battery.

2. DO NOT SMOKE OR WORK NEAR AN OPEN FLAME WHEN WORKING ON FUEL SYSTEM

3. KEEP GASOLINE AWAY FROM RUBBER OR LEATHER PARTS

4. MAINTENANCE PRECAUTIONS

(a) In event of engine misfire, these precautions should be taken.

- (1) Check proper connection to battery terminals, etc.
- (2) After repair work, check that the ignition coil terminals and all other ignition system lines are reconnected securely.
- (3) When cleaning the engine compartment, be especially careful to protect the electrical system from water.

(b) Precautions when handling the oxygen sensor.

- (1) Do not allow the oxygen sensor to drop or hit against an object.
- (2) Do not allow the sensor to come into contact with water.

5. IF VEHICLE IS EQUIPPED WITH A MOBILE RADIO SYSTEM (HAM, CB, ETC.)

If the vehicle is equipped with a mobile communication system, refer to the precaution in the IN section.

6. AIR INDUCTION SYSTEM

- (a) Separation of the engine oil dipstick, oil filler cap, PCV hose, etc. may cause the engine to run out of tune.
- (b) Disconnection, looseness or cracks in the parts of the air induction system between the throttle body and cylinder head will allow air suction and cause the engine to run out of tune.

7. ELECTRONIC CONTROL SYSTEM

- (a) Before removing SFI wiring connectors, terminals, etc., first disconnect the power by either turning the ignition switch to LOCK or disconnecting the negative (-) terminal cable from the battery.

HINT:

Always check the diagnostic trouble code before disconnecting the negative (-) terminal cable from the battery.

- (b) When installing the battery, be especially careful not to incorrectly connect the positive (+) and negative (-) cables.
- (c) Do not permit parts to receive a severe impact during removal or installation. Handle all SFI parts carefully, especially the ECM.
- (d) Be careful during troubleshooting as there are numerous transistor circuit, and even slight terminal contact can cause further troubles.
- (e) Do not open the ECM cover.
- (f) When inspecting during rainy weather, take care to prevent entry of water. Also, when washing the engine compartment, prevent water from getting on the SFI parts and wiring connectors.
- (g) Parts should be replaced as an assembly.
- (h) Care should be taken when pulling out and inserting wiring connectors.
 - (1) Release the lock and pull out the connector, pulling on the connectors.
 - (2) Fully insert the connector and check that it is locked.

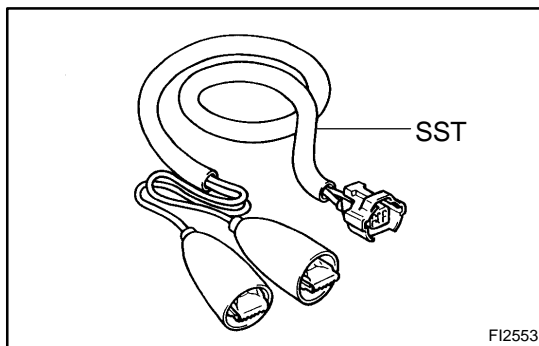

- (i) Use SST for inspection or test of the injector or its wiring connector.
SST 09842-30070

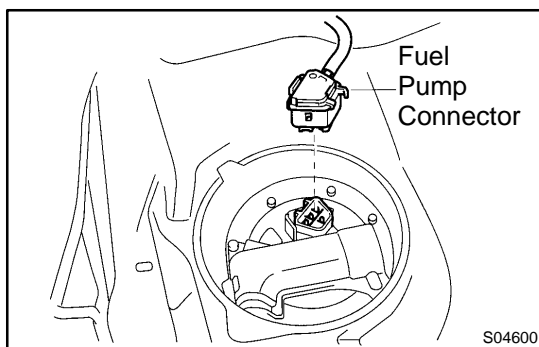

8. FUEL SYSTEM

- (a) When disconnecting the high fuel pressure line, a large amount of gasoline will spill out, so observe these procedures:
 - (1) Disconnect the fuel pump connector.
 - (2) Start the engine. After the engine has stopped on its own, turn the ignition switch to LOCK.
 - (3) Put a container under the connection.
 - (4) Slowly loosen the connection.
 - (5) Disconnect the connection.
 - (6) Plug the connection with a rubber plug.

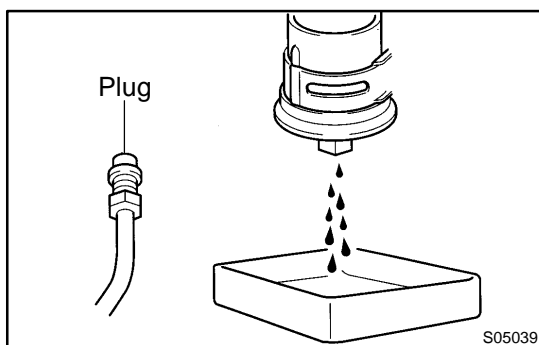

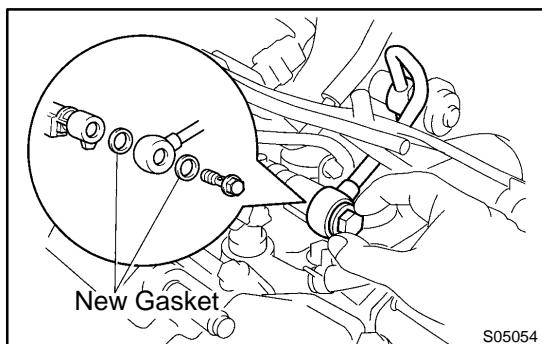

- (b) When connecting the union bolt on the high pressure pipe union, observe these procedures:
- (1) Always use 2 new gaskets.
 - (2) Tighten the union bolt by hand.
 - (3) Tighten the union bolt to the specified torque.

Torque: 32.5 N·m (330 kgf·cm, 24 ft·lbf)

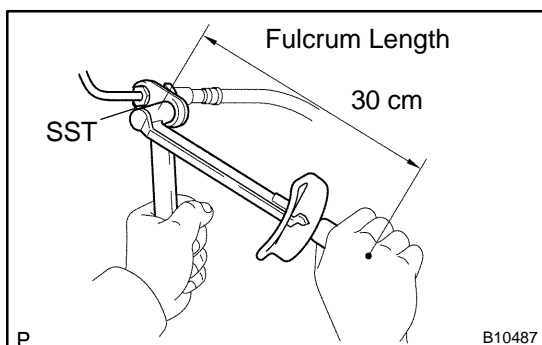

- (c) When connecting the flare nut on the high pressure pipe union, observe these procedures:
- (1) Apply a light coat of engine oil to the flare nut, and tighten the flare nut by hand.
 - (2) Using SST, tighten the flare nut to specified torque.
- SST 09023-38400

NOTICE:

Do not rotate the fuel pipe, when tightening the flare nut.

Torque: 24 N·m (245 kgf·cm, 18 ft·lbf) for using SST

HINT:

Use a torque wrench with a fulcrum length of 30 cm (11.81 in.).

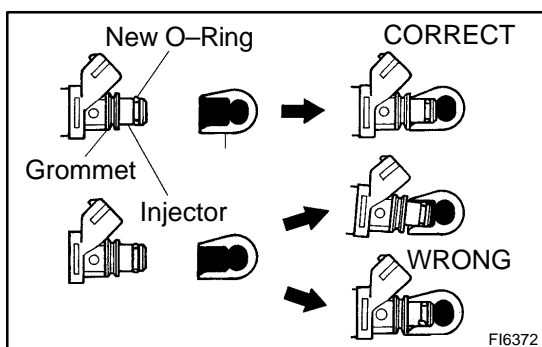

- (d) Observe these precautions when removing and installing the injectors.
- (1) Never reuse the O-ring.
 - (2) When placing a new O-ring on the injector, take care not to damage it in any way.
 - (3) Coat a new O-ring with spindle oil or gasoline before installing—never use engine, gear or brake oil.

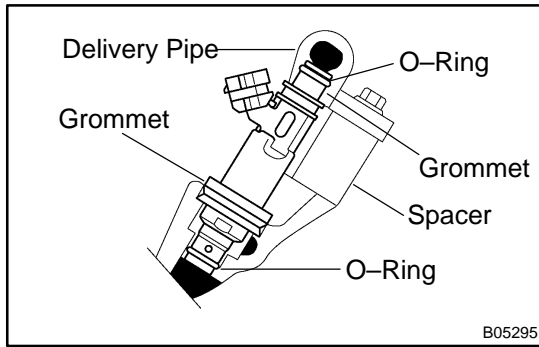

- (e) Install the injector to the delivery pipe and intake manifold, as shown in the illustration. Before installing the injector, must apply spindle oil or gasoline on the place where a delivery pipe or an intake manifold touches an O-ring of the injector.

- (f) Observe these precautions when disconnecting the fuel tube connector (quick type).
- (1) Check if there is any dirt like mud on the pipe and around the connector before disconnecting them and clean the dirt away.
 - (2) Be sure to disconnect with hands.

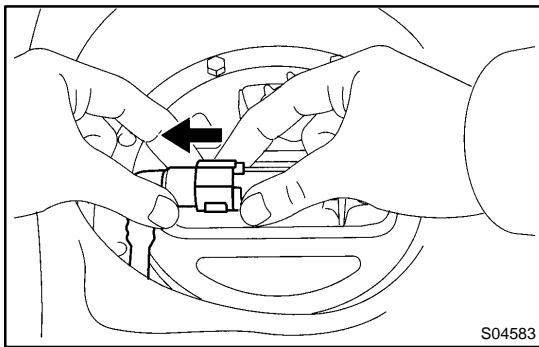

- (3) When the connector and the pipe are stuck, pinch the retainer between the hands, push and pull the connector to free to disconnect and pull it out. Do not use any tool at this time.
- (4) Inspect if there is any dirt or the likes on the seal surface of the disconnected pipe and clean it away.

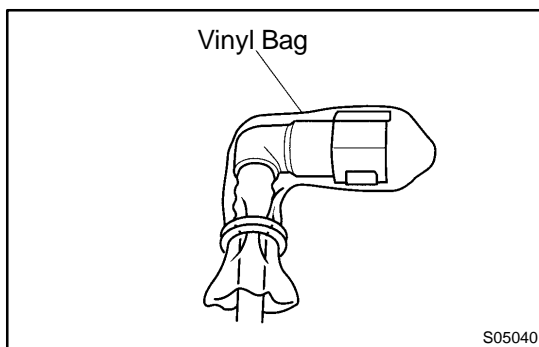

- (5) Prevent the disconnected pipe and connector from damaging and mixing foreign objects by covering them with a vinyl bag.

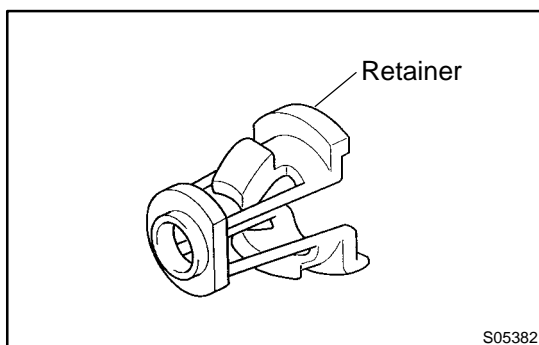

- (g) Observe these precautions when connecting the fuel tube connector (quick type).
- (1) Do not reuse the retainer removed from the pipe.
 - (2) Must use hands without using tools when to remove the retainer from the pipe.
 - (3) Check if there is any damage or foreign objects on the connected part of the pipe.

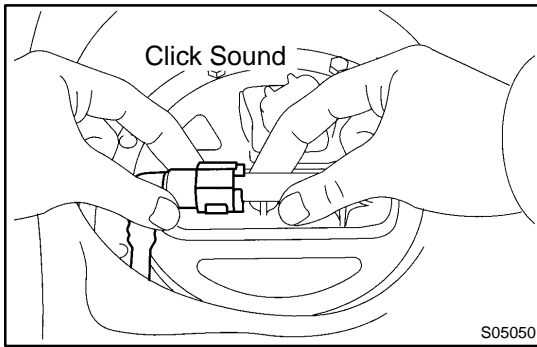

- (4) Match the axis of the connector with axis of the pipe, and push in the connector until the retainer makes a "click" sound. In case that the connections is tight, apply little amount of new engine oil on the tip of the pipe.
- (5) After having finished the connection, check if the pipe and the connector are securely connected by pulling them.
- (6) Check if there is any fuel leakage.

- (h) Observe these precautions when handling nylon tube.
- (1) Pay attention not to turn the connected part of the nylon tube and the quick connector with force when connecting them.
 - (2) Pay attention not to kink the nylon tube.
 - (3) Do not remove the EPDM protector on the outside of the nylon tube.
 - (4) Must not close the piping with the nylon tube by bending it.

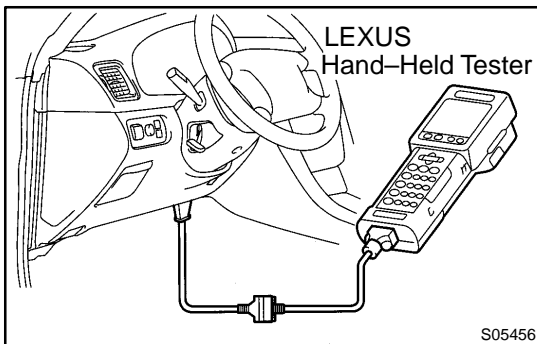

- (i) Check that there are no fuel leaks after doing maintenance anywhere on the fuel system.
- (1) Connect the LEXUS hand-held tester to the DLC3.
 - (2) Turn the ignition switch ON and push the LEXUS hand-held tester main switch ON.

NOTICE:**Do not start the engine.**

- (3) Select the active test mode on the LEXUS hand-held tester.
- (4) Please refer to the LEXUS hand-held tester operator's manual for further details.
- (5) If you have no LEXUS hand-held tester, connect the positive (+) and negative (-) leads from the battery to the fuel pump connector (See page [SF-6](#)).
- (6) Check that there are no leaks from any part of the fuel system.
- (7) Turn the ignition switch to LOCK.
- (8) Disconnect the LEXUS hand-held tester from the DLC3.

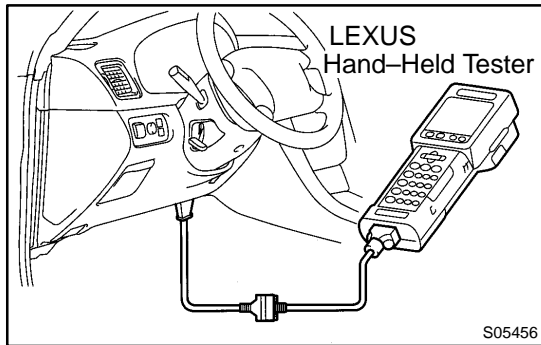

FUEL PUMP ON-VEHICLE INSPECTION

SF05N-03

1. CHECK FUEL PUMP OPERATION

- (a) Connect the LEXUS hand-held tester to the DLC3.
- (b) Turn the ignition switch ON and push the LEXUS hand-held tester main switch ON.

NOTICE:

Do not start the engine.

- (c) Select the ACTIVE TEST mode on the LEXUS hand-held tester.
- (d) Please refer to the LEXUS hand-held tester operator's manual for further details.
- (e) If you have no LEXUS hand-held tester, connect the positive (+) and negative (-) leads from the battery to the fuel pump connector. (See step 7.)

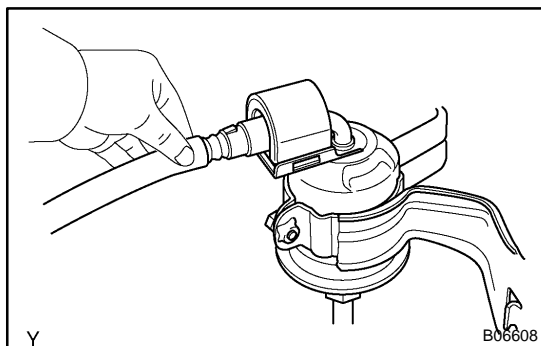

- (f) Check that there is pressure in the fuel inlet hose from the fuel filter.

HINT:

If there is fuel pressure, you will hear the sound of fuel flowing. If there is no pressure, check the fusible link, fuses, EFI main relay, fuel pump, ECM and wiring connections.

- (g) Turn the ignition switch OFF.
- (h) Disconnect the LEXUS hand-held tester from the DLC3.

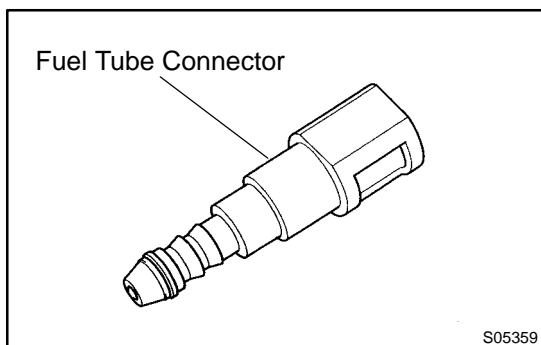

2. CHECK FUEL PRESSURE

- (a) Check the battery positive voltage is above 12 V.
- (b) Disconnect the negative (-) terminal cable from the battery.
- (c) Purchase the new No.1 fuel pipe and take out the fuel tube connector from its pipe.
Part No. 23801-20060

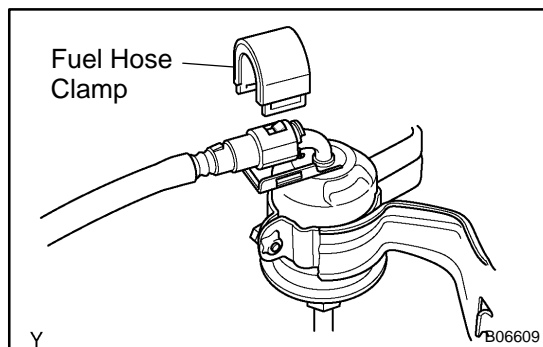

- (d) Remove the fuel hose clamp.

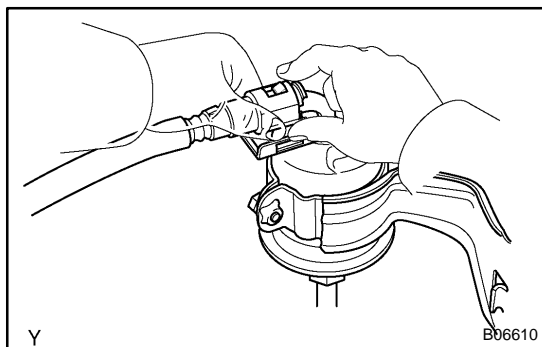

- (e) Disconnect the No.1 fuel pipe (fuel tube connector) from the fuel filter outlet.

CAUTION:

- Perform disconnecting operations of the fuel tube connector (quick type) after observing the precautions (See page SF-1).
- As there is retained pressure in the fuel pipe line, prevent it from splashing inside the engine compartment.

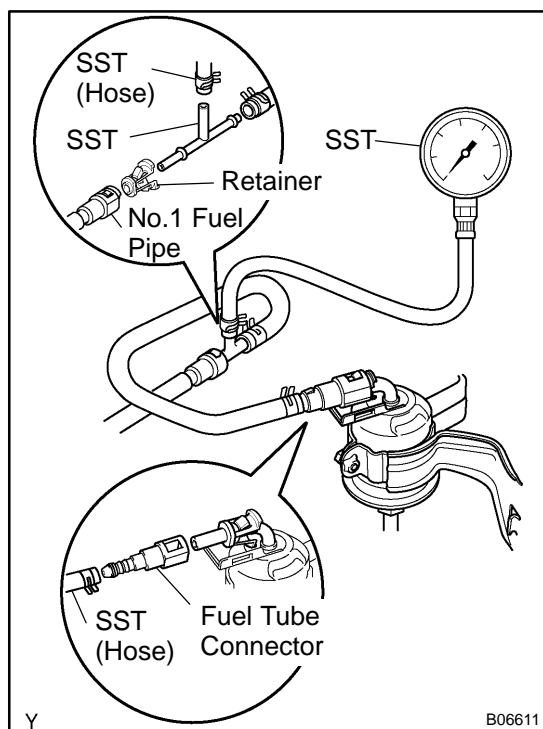

- (f) Install SST (pressure gauge) as shown in the illustration by using SST and fuel tube connector.

SST 09268-41047, 09268-41250, 09268-45012

- (g) Wipe off any splattered gasoline.
 (h) Reconnect the negative (-) terminal cable to the battery.
 (i) Connect the LEXUS hand held tester to the DLC3.
 (See step 1. check fuel pump operation (a) to (e))
 (j) Measure the fuel pressure.

Fuel pressure:

301 - 347 kPa (3.1 - 3.5 kgf/cm², 44 - 50 psi)

If pressure is high, replace the fuel pressure regulator.

If pressure is low, check the fuel hoses, fuel hose connections, fuel pump, fuel filter and fuel pressure regulator.

- (k) Disconnect the LEXUS hand-held tester from the DLC3.
 (l) Start the engine.
 (m) Measure the fuel pressure at idle.

Fuel pressure:

301 - 347 kPa (3.1 - 3.5 kgf/cm², 44 - 50 psi)

- (n) Stop the engine.
 (o) Check that the fuel pressure remains as specified for 5 minutes after the engine has stopped.

Fuel pressure:

147 kPa (1.5 kgf/cm², 21 psi) or more

If pressure is not as specified, check the fuel pump, pressure regulator and/or injectors.

- (p) After checking fuel pressure, disconnect the negative (-) terminal cable from the battery and carefully remove the SST and fuel tube connector to prevent gasoline from splashing.

SST 09268-41047, 09268-41250, 09268-45012

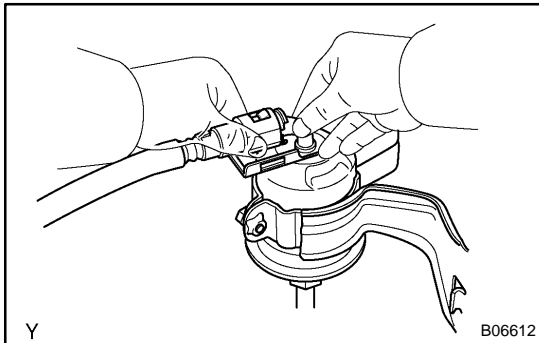

- (q) Reconnect the No.1 fuel pipe (fuel tube connector).

CAUTION:

Perform connecting operations of the fuel tube connector (quick type) after observing the precautions (See page SF-1).

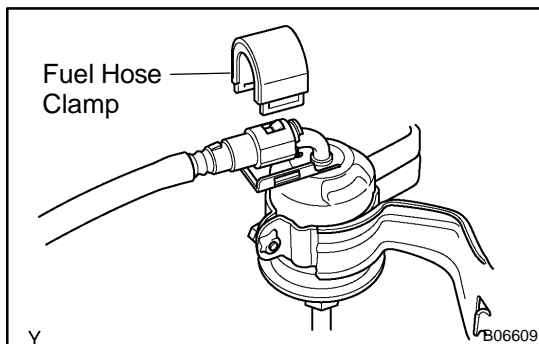

- (r) Surely install the fuel hose clamp to the fuel filter with "click" sound.

- (s) After installing the clamp, check that the clamp is fixed by pulling up the clamp.

- (t) Reconnect the negative (-) terminal cable to the battery.

- (u) Check for fuel leaks.

3. REMOVE REAR SEAT CUSHION

4. REMOVE FLOOR SERVICE HOLE COVER

5. DISCONNECT FUEL PUMP & SENDER GAUGE CONNECTOR

6. INSPECT FUEL PUMP RESISTANCE

Using an ohmmeter, measure the resistance between terminals 4 and 5.

Resistance: 0.2 – 3.0 Ω at 20°C (68°F)

If the resistance is not as specified, replace the fuel pump.

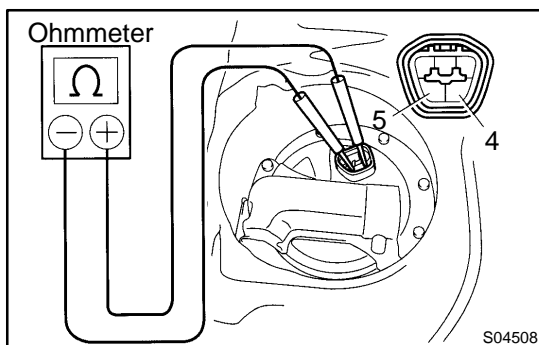

7. INSPECT FUEL PUMP OPERATION

Connect the positive (+) lead from the battery to terminal 4 of the connector, and the negative (-) lead to terminal 5. Check that the fuel pump operates.

NOTICE:

- These tests must be done quickly (within 10 seconds) to prevent the coil burning out.
- Keep the fuel pump as far away from the battery as possible.
- Always do the switching at the battery side.

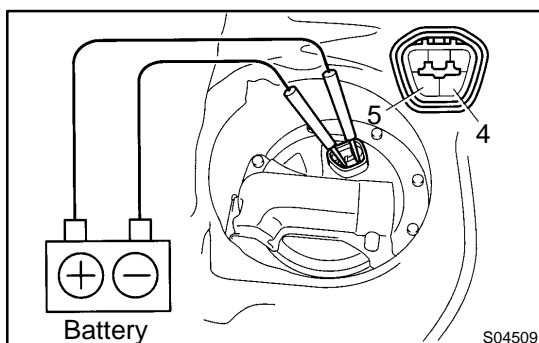

If operation is not as specified, replace the fuel pump or lead wire.

8. RECONNECT FUEL PUMP & SENDER GAUGE CONNECTOR
9. REINSTALL FLOOR SERVICE HOLE COVER
10. REINSTALL REAR SEAT CUSHION

COMPONENTS

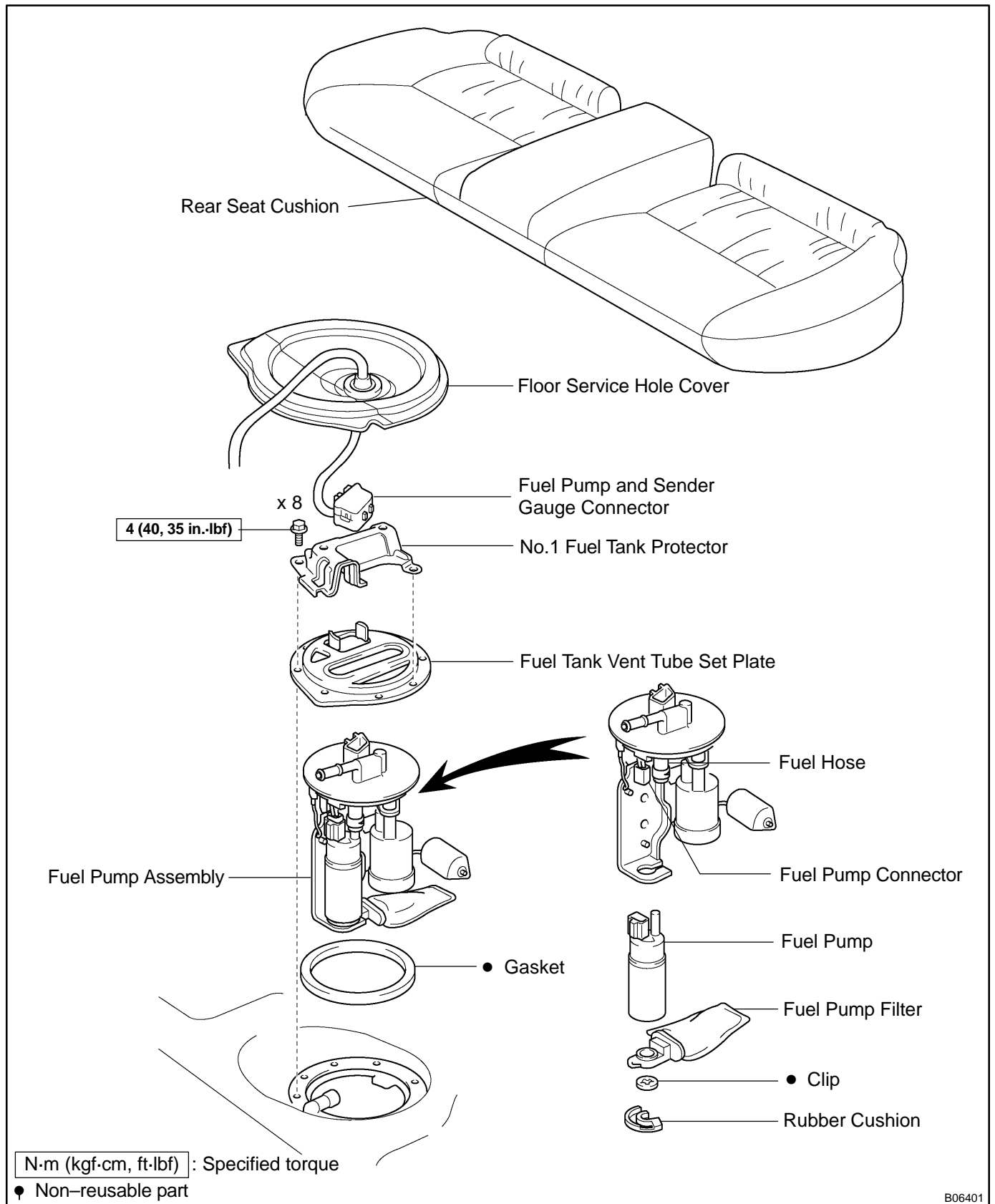

REMOVAL

CAUTION:

Do not smoke or work near an open flame when working on the fuel pump.

1. REMOVE REAR SEAT CUSHION
2. REMOVE FLOOR SERVICE HOLE COVER
 - (a) Take out the floor carpet.
 - (b) Remove the service hole cover.

HINT:

At the time of installation, please refer to the following items. Check for fuel leakage.

3. DISCONNECT FUEL PUMP & SENDER GAUGE CONNECTOR
4. REMOVE NO.1 FUEL TANK PROTECTOR

Remove the 2 bolts and No.1 fuel tank protector.
Torque: 4 N·m (40 kgf·cm, 35 in.-lbf)

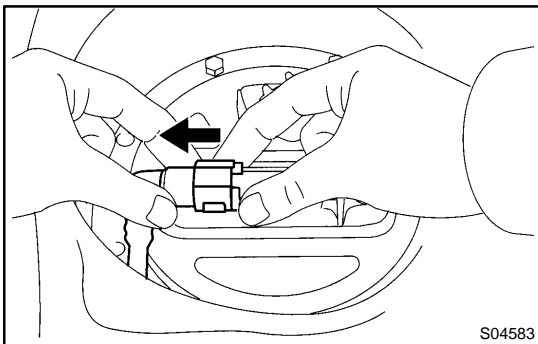

5. DISCONNECT FUEL TUBE (FUEL TUBE CONNECTOR)

CAUTION:

- Perform disconnecting and connecting operations of the fuel tube connector (quick type) after observing the precautions.
- As there is retained pressure in the fuel pipe line, prevent it from splashing inside the vehicle compartment.

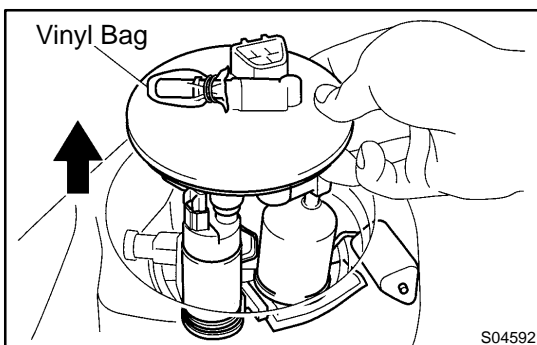

6. REMOVE FUEL PUMP ASSEMBLY FROM FUEL TANK
 - (a) Remove the 6 bolts and fuel tank vent tube set plate.
Torque: 4 N·m (40 kgf·cm, 35 in.-lbf)
 - (b) Pull out the fuel pump assembly.
 - (c) Remove the gasket from the pump assembly.

NOTICE:

- Do not damage the fuel pump filter.
- Be careful that the arm of the sender gauge should not bent.

HINT:

At the time of installation, please refer to the following items. Install a new gasket to the pump assembly.

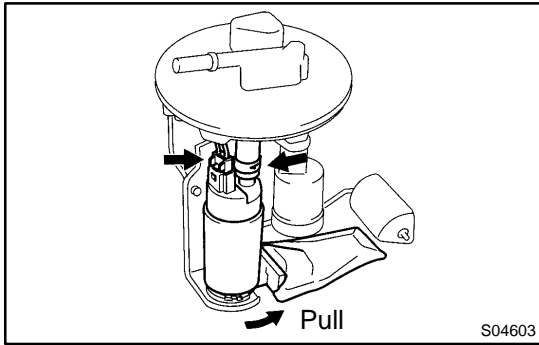
**7. DISCONNECT FUEL PUMP CONNECTOR****8. REMOVE FUEL PUMP FROM FUEL PUMP BRACKET**

- (a) Pull off the lower side of the fuel pump from the pump bracket.
- (b) Disconnect the fuel hose from the fuel pump, and remove the fuel pump.
- (c) Remove the rubber cushion from the fuel pump.

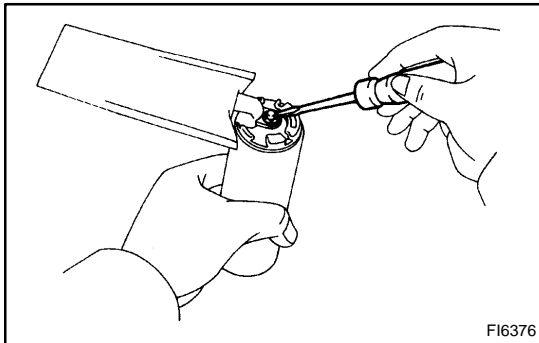
**9. REMOVE FUEL PUMP FILTER FROM FUEL PUMP**

- (a) Using a small screwdriver, remove the clip.
- (b) Pull out the pump filter.

HINT:

At the time of installation, please refer to the following items.
Install the pump filter with a new clip.

INSTALLATION

Installation is in the reverse order of removal (See page [SF-11](#)).

FUEL PRESSURE REGULATOR COMPONENTS

SF05R-03

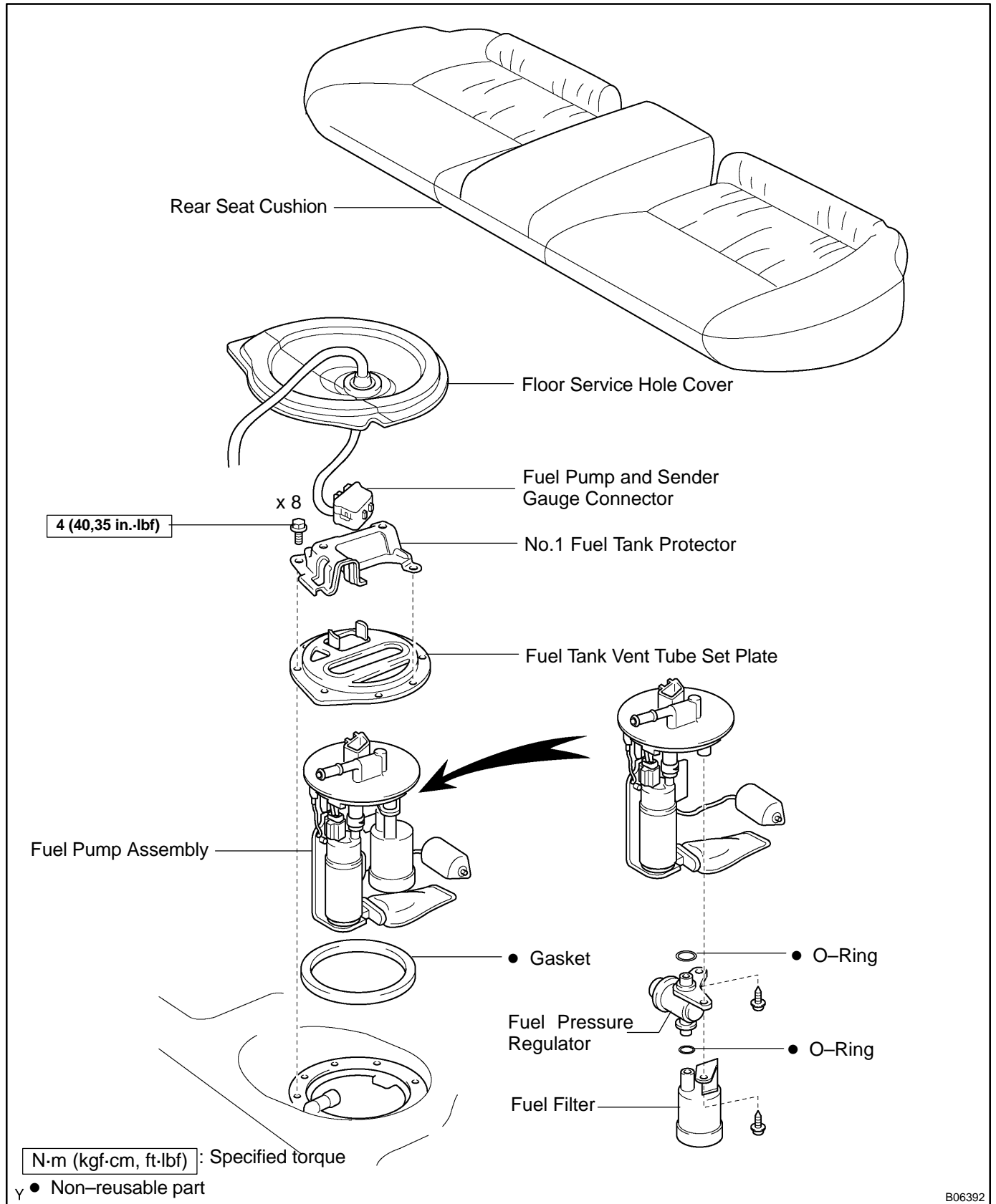

B06392

REMOVAL

1. REMOVE FUEL PUMP ASSEMBLY FROM FUEL TANK
(See page SF-11)

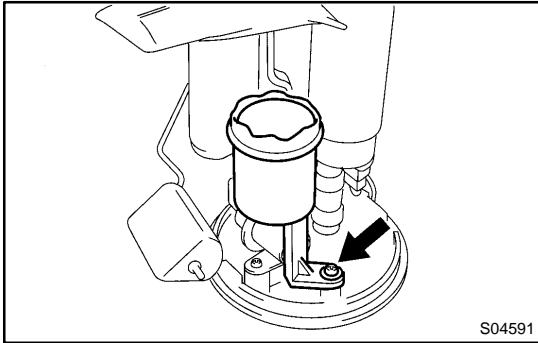

2. REMOVE FUEL FILTER

- (a) Remove the screw, and pull out the fuel filter.
Torque: 2.0 N·m (20 kgf-cm, 17 in.-lbf)
- (b) Remove the O-ring from the fuel filter.

HINT:

At the time of installation, please refer to the following items.
Apply a light coat of gasoline to a new O-ring, and install it to the fuel filter.

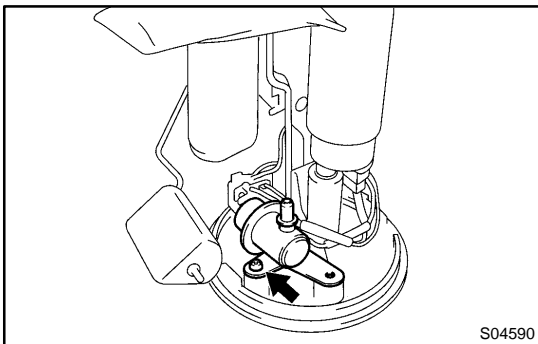

3. REMOVE FUEL PRESSURE REGULATOR

- (a) Remove the screw, and pull out the pressure regulator.
Torque: 2.0 N·m (20 kgf-cm, 17 in.-lbf)
- (b) Remove the O-ring from the pressure regulator.

HINT:

At the time of installation, please refer to the following items.
Apply a light coat of gasoline to a new O-ring, and install it to the pressure regulator.

INSTALLATION

Installation is in the reverse order of removal (See page [SF-15](#)).

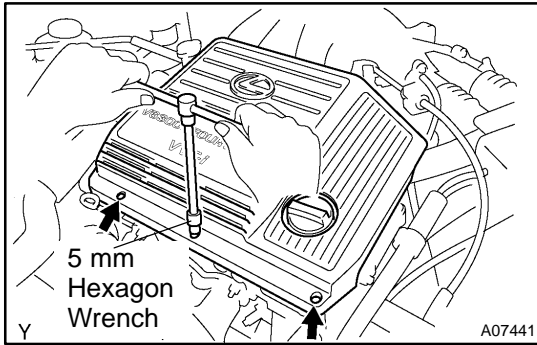

INJECTOR ON-VEHICLE INSPECTION

SF072-03

1. REMOVE V-BANK COVER

- Using a 5 mm hexagon wrench, remove the 3 cap nuts.
- Loosen the V-bank cover fastener counterclockwise.
- Remove the V-bank cover.

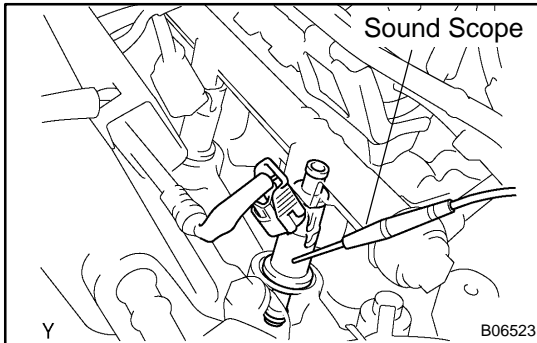

2. INSPECT INJECTOR OPERATION

Check operation sound from each injector.

- With the engine running or cranking, use a sound scope to check that there is normal operating noise in proportion to engine speed.
- If you have no sound scope, you can check the injector operating vibration with your finger.

If no sound or unusual sound is heard, check the wiring connector, injector or injection signal from the ECM.

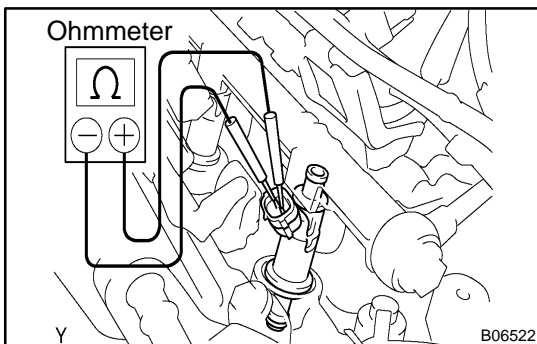

3. INSPECT INJECTOR RESISTANCE

- Disconnect the injector connector.
- Using an ohmmeter, measure the resistance between the terminals.

Resistance: 13.4 – 14.2 Ω at 20°C (68°F)

If the resistance is not as specified, replace the injector.

- Reconnect the injector connector.

4. REINSTALL V-BANK COVER

- Using 5 mm hexagon wrench, install the V-bank cover with the 3 cap nuts.
- Press down the V-bank cover fastener.

COMPONENTS

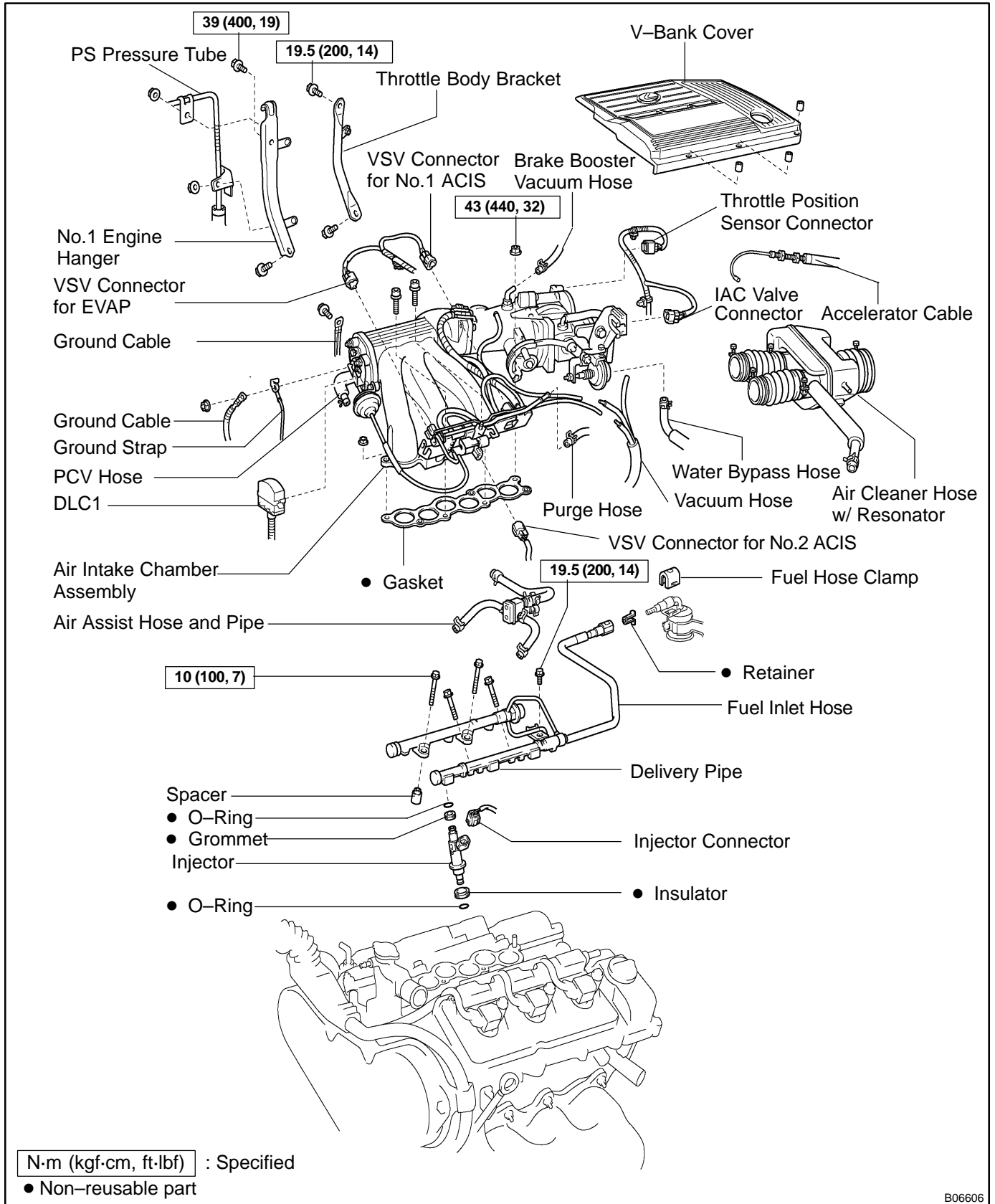

B06606

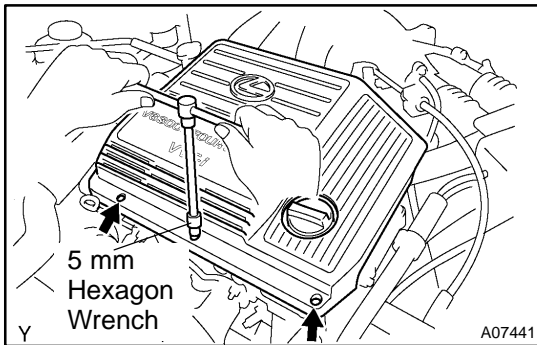

REMOVAL

1. REMOVE V-BANK COVER

- (a) Using a 5 mm hexagon wrench, remove the 3 cap nuts.
- (b) Loosen the V-bank cover fastener counterclockwise.
- (c) Remove the V-bank cover.

2. REMOVE AIR CLEANER HOSE WITH RESONATOR

3. REMOVE AIR INTAKE CHAMBER ASSEMBLY

(See page [EM-31](#))

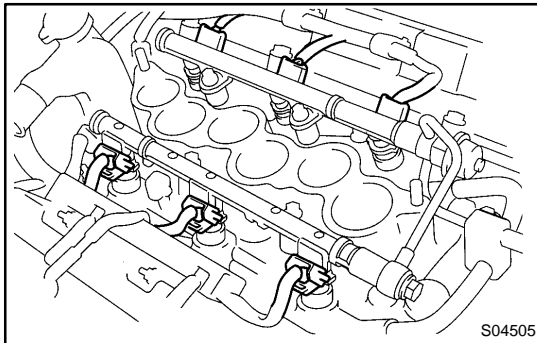

4. DISCONNECT INJECTOR CONNECTORS

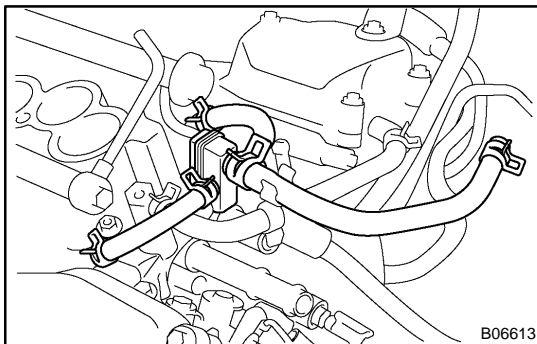

5. REMOVE AIR ASSIST HOSES AND PIPE

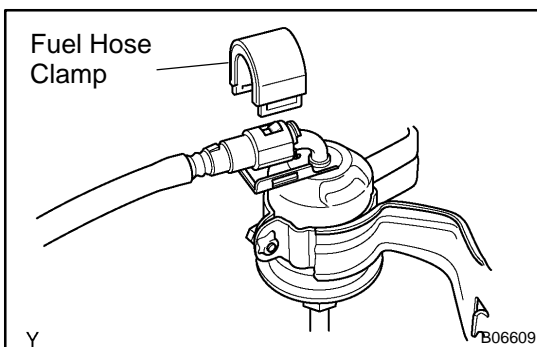

6. DISCONNECT NO.1 FUEL PIPE

- (a) Remove the fuel hose clamp.

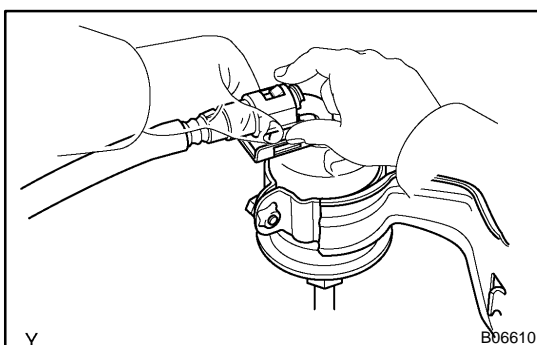

- (b) Disconnect the No.1 fuel pipe (fuel tube connector) from the fuel filter outlet.

CAUTION:

- Perform disconnecting operations of the fuel tube connector (quick type) after observing the precautions. (See page [SF-1](#))
- As there is retained pressure in the fuel pipe line, prevent it from splashing inside the engine compartment.

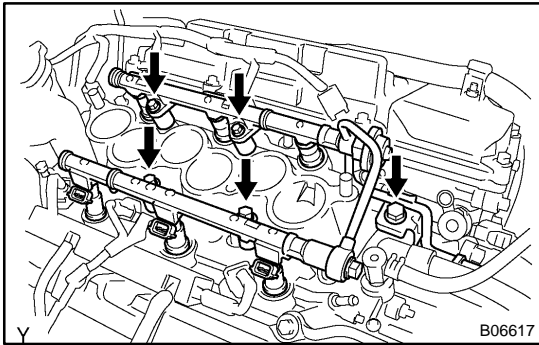

7. REMOVE DELIVERY PIPES AND INJECTORS

NOTICE:

- Be careful not to drop the injectors when removing the delivery pipes.
- Pay attention to put any hung load on the injector to and from the side direction.

- (a) Remove the 5 bolts and delivery pipes together with the 6 injectors and No.1 fuel pipe.
- (b) Remove the 4 spacers from the intake manifold.
- (c) Pull out the 6 injectors from the delivery pipes.
- (d) Remove the 2 O-rings and 2 grommets from each injector.

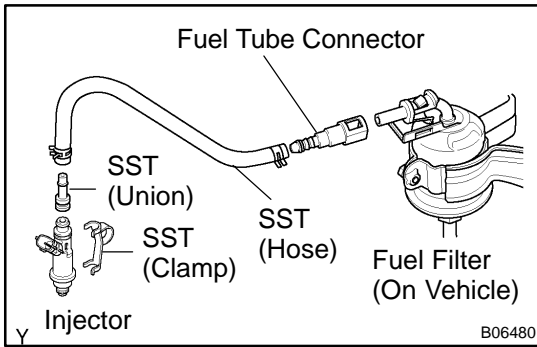

INSPECTION

1. INSPECT INJECTOR INJECTION

CAUTION:

Keep injector clear of sparks during the test.

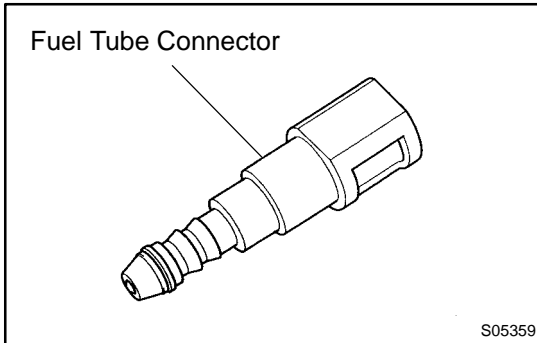

- (a) Purchase the new No.1 fuel pipe and take out the fuel tube connector from its pipe.
Part No. 23801-20060

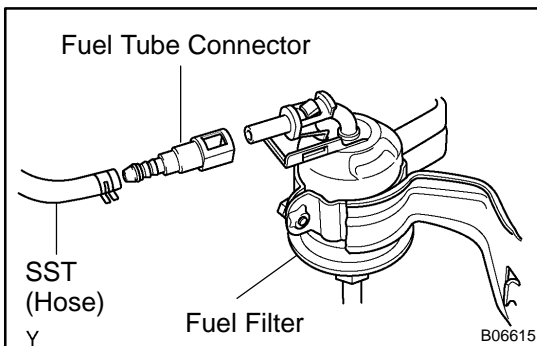

- (b) Connect SST (hose) and fuel tube connector to the fuel filter outlet.
SST 09268-41047

CAUTION:

Preform connecting operations of the fuel tube connector (quick type) after observing the precautions.
(See page SF-1)

HINT:

Use the vehicle fuel filter.

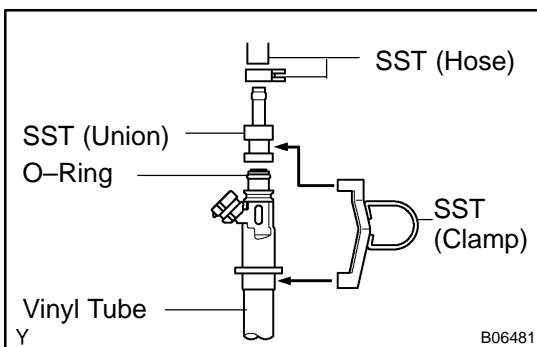

- (c) Install the grommet and O-Ring to the injector.
(d) Connect SST (union and hose) to the injector, and hold the injector and union with SST (clamp).
SST 09268-41047

- (e) Put the injector into a graduated cylinder.

HINT:

Install a suitable vinyl hose onto the injector to prevent gasoline from splashing out.

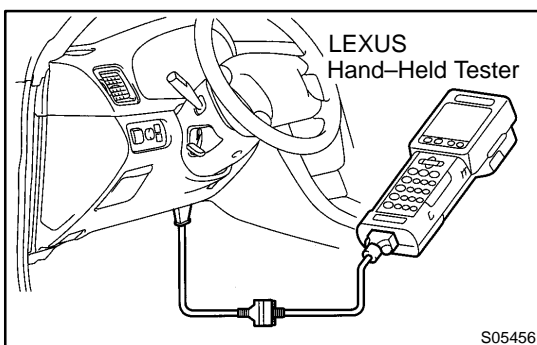

- (f) Connect the LEXUS hand-held tester to the DLC3.
(g) Turn the ignition switch ON and push the LEXUS hand-held tester main switch ON.

NOTICE:

Do not start the engine.

- (h) Select the ACTIVE TEST mode on the LEXUS hand-held tester.
(i) Please refer to the LEXUS hand-held tester operator's manual for further details.

- (j) If you have no LEXUS hand-held tester, connect the positive (+) and negative (-) leads from the battery to the fuel pump connector. (See page SF-6)

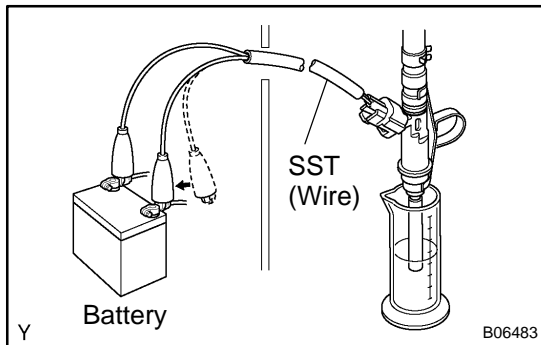

- (k) Connect SST (wire) to the injector and battery for 15 seconds, and measure the injection volume with a graduated cylinder. Test each injector 2 or 3 times.

SST 09842-30070

Volume:

60 – 73 cm³ (3.4 – 4.5 cu in.) per 15 sec.

Difference between each injector:

13 cm³ (0.8 cu in.) or less

If the injection volume is not as specified, replace the injector.

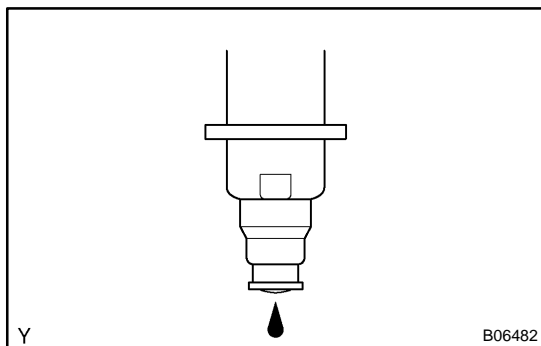

2. INSPECT LEAKAGE

- (a) In the condition above, disconnect the test probes of SST (wire) from the battery and check the fuel leakage from the injector.

SST 09842-30070

Fuel drop: 1 drop or less per 12 minutes

- (b) Turn the ignition switch OFF.
 (c) Disconnect the negative (-) terminal cable from the battery.
 (d) Remove the SST and fuel tube connector.
 SST 09268-41047, 09842-30070

CAUTION:

- Perform disconnecting operations of the fuel tube connector (quick type) after observing the precautions. (See page SF-1)
 - As there is retained pressure in the fuel pipe line, prevent it from splashing inside the engine compartment.
- (e) Disconnect the LEXUS hand-held tester from the DLC3.

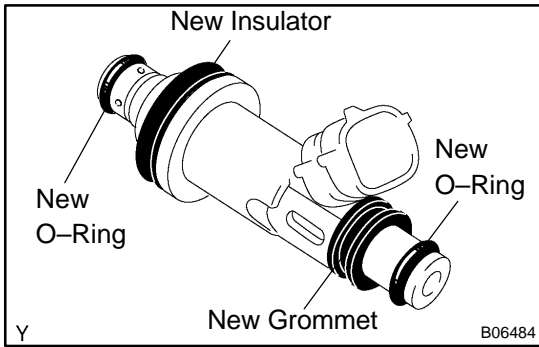

INSTALLATION

1. INSTALL INJECTORS AND DELIVERY PIPES

- (a) Install new insulator and grommet to each injector.
- (b) Apply a light coat of spindle oil or gasoline to 2 new O-rings and install them to each injector.

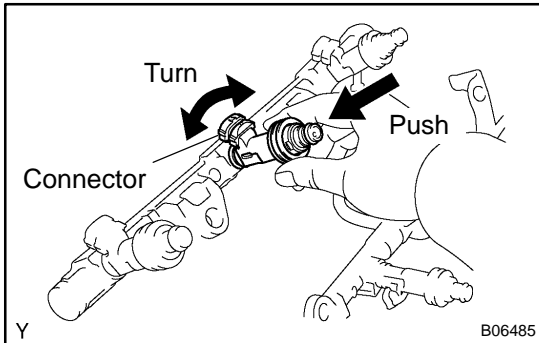

- (c) Apply a light coat of spindle oil or gasoline on the place where a delivery pipe touches an O-ring of the injector.
- (d) While turning the injector clockwise and counterclockwise, push it to the delivery pipes. Install the 6 injectors.
- (e) Position the injector connector outward.

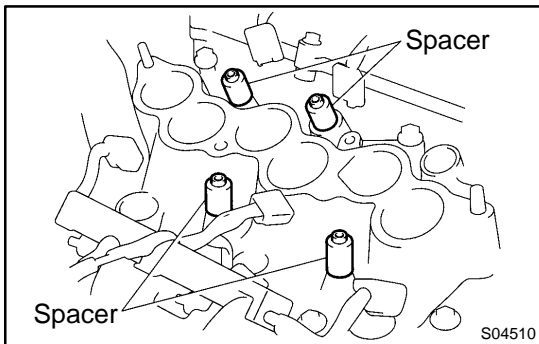

- (f) Place the 4 spacers in position on the intake manifold.

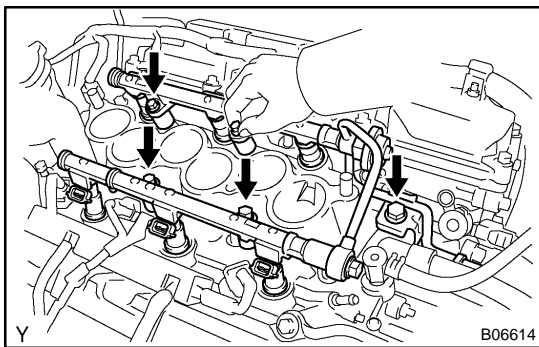

- (g) Apply a light coat of spindle oil or gasoline on the place where a intake manifold touches an O-ring of the injector.
- (h) Place the delivery pipes and fuel pipe together with the 6 injectors in position on the intake manifold.
- (i) Temporarily install the 4 bolts holding the delivery pipes to the intake manifold.
- (j) Temporarily install the bolt holding the No.1 fuel pipe to the intake manifold.

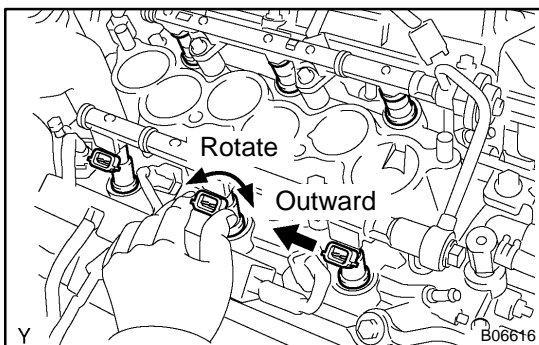

- (k) Check that the injectors rotate smoothly.

HINT:

If injectors do not rotate smoothly, the probable cause is incorrect installation of O-rings. Replace the O-rings.

- (l) Position the injector connector outward.

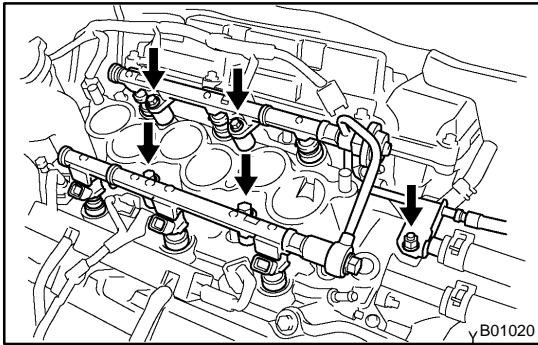

- (m) Tighten the 4 bolts holding the delivery pipes to the intake manifold.
Torque: 10 N·m (100 kgf·cm, 7 ft·lbf)
- (n) Tighten the bolt holding the No.1 fuel pipe to the intake manifold.
Torque: 19.5 N·m (200 kgf·cm, 14 ft·lbf)

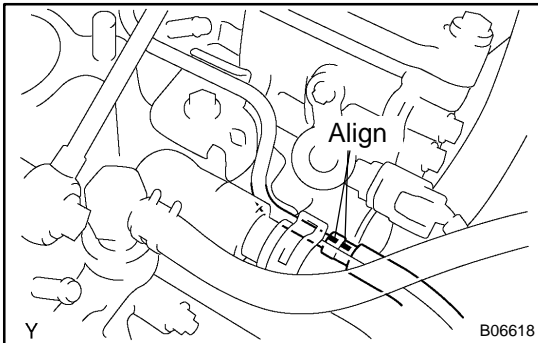

2. CONNECT NO.1 FUEL PIPE

- (a) Align the alignment marks (white paint) on the No.1 fuel pipe.

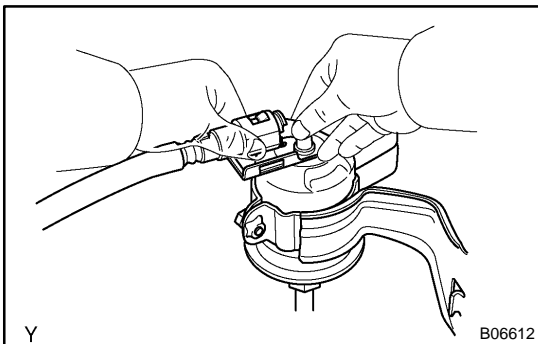

- (b) Connect the No.1 fuel pipe (fuel tube connector) to the fuel filter.

CAUTION:

Perform connecting operations of the fuel tube connector (quick type) after observing the precautions.

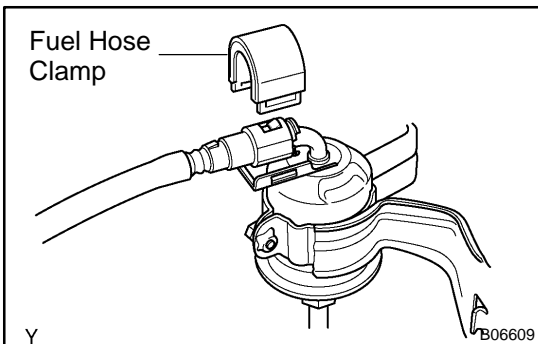

- (c) Surely install the fuel hose clamp to the fuel filter with "click" sound.
- (d) After installing the clamp, check that the clamp is fixed by pulling up the clamp.

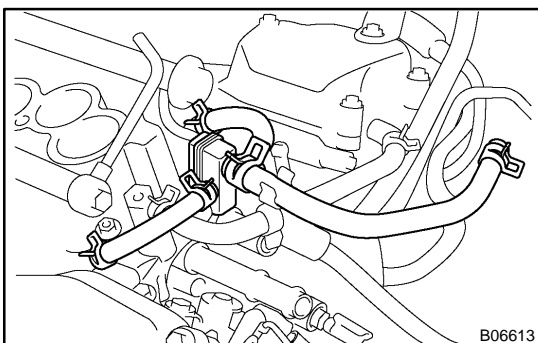

3. INSTALL AIR ASSIST HOSES AND PIPE
4. CONNECT INJECTOR CONNECTORS
5. INSTALL AIR INTAKE CHAMBER ASSEMBLY
 (See page [EM-59](#))

6. INSTALL AIR CLEANER HOSE WITH RESONATOR
7. INSTALL V-BANK COVER

- (a) Using 5 mm hexagon wrench, install the V-bank cover with the 3 cap nuts.
- (b) Press down the V-bank cover fastener.

8. CHECK FOR FUEL LEAKS

FUEL TANK AND LINE COMPONENTS

SF05V-03

CAUTION:

Always use new gaskets when replacing the fuel tank or component parts.
Apply the proper torque to all parts tightened.

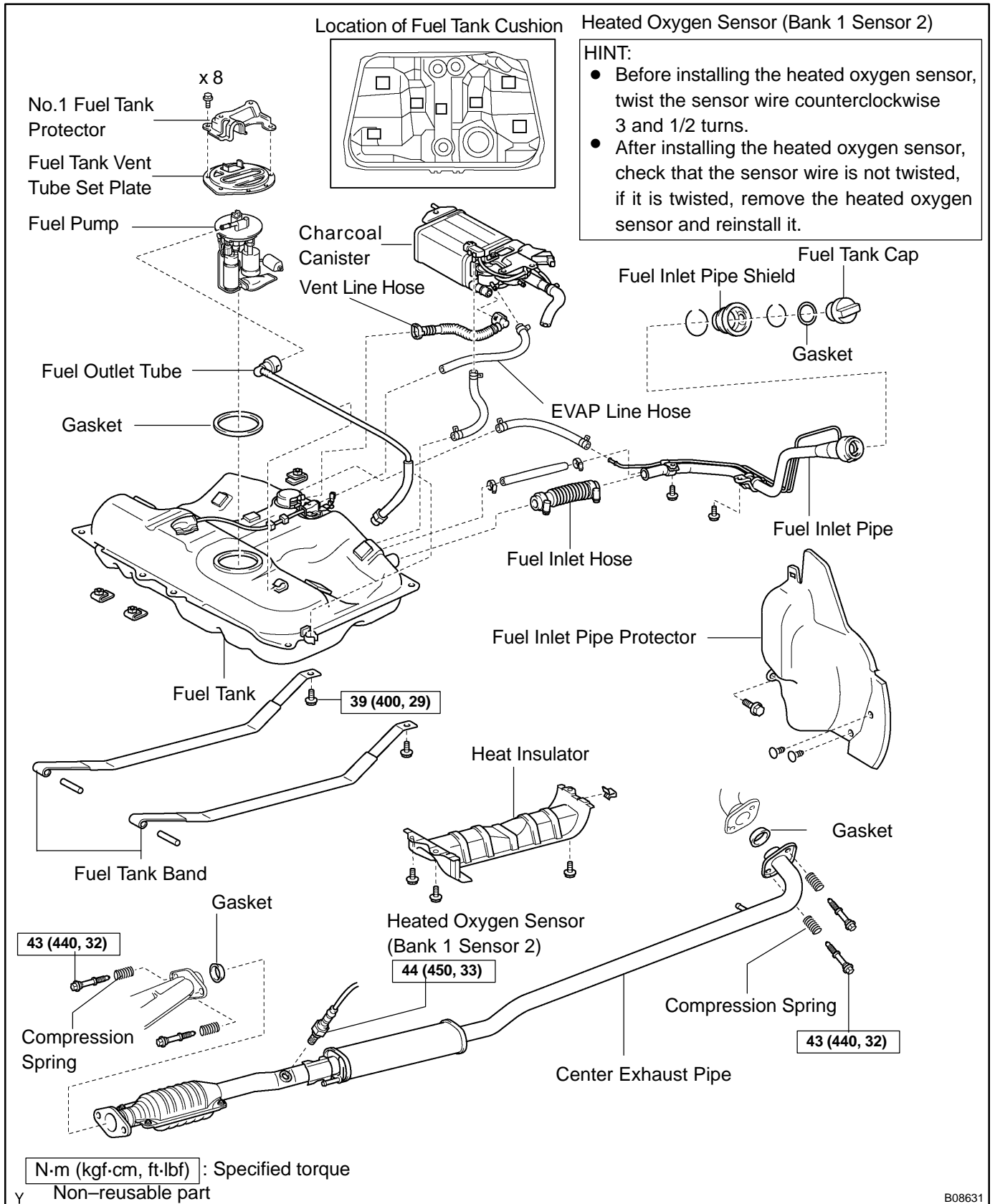

B08631

2001 LEXUS ES300 (RM831U)

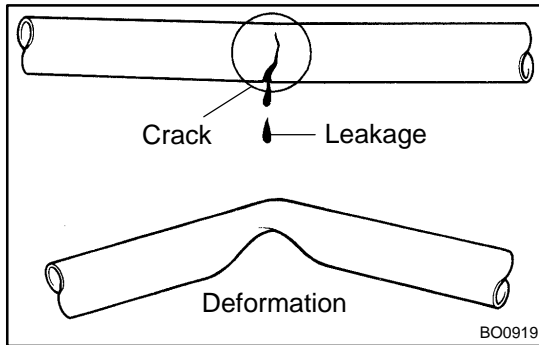

INSPECTION

INSPECT FUEL TANK AND LINE

- Check the fuel lines for cracks or leakage, and all connections for deformation.
- Check the fuel tank vapor vent system hoses and connections for looseness, sharp bends or damage.
- Check the fuel tank for deformation, cracks, fuel leakage or tank band looseness.
- Check the filler neck for damage or fuel leakage.
- Hose and pipe connections are as shown in the illustration.

If a problem is found, repair or replace the parts as necessary.

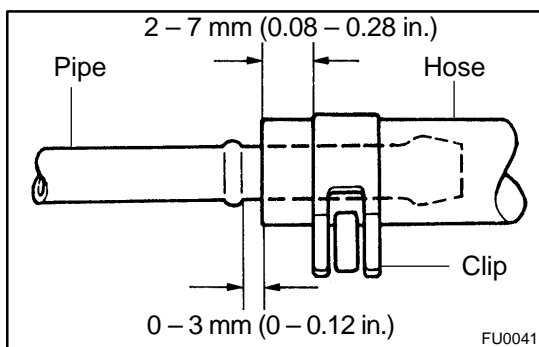
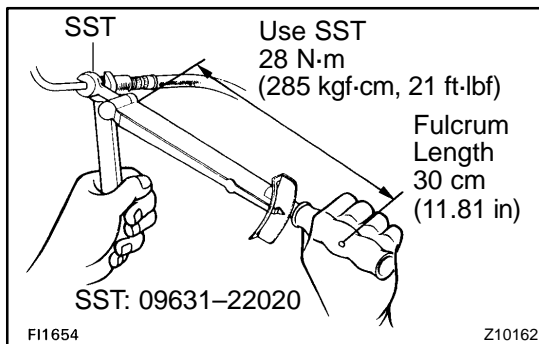

MASS AIR FLOW (MAF) METER COMPONENTS

SF05X-03

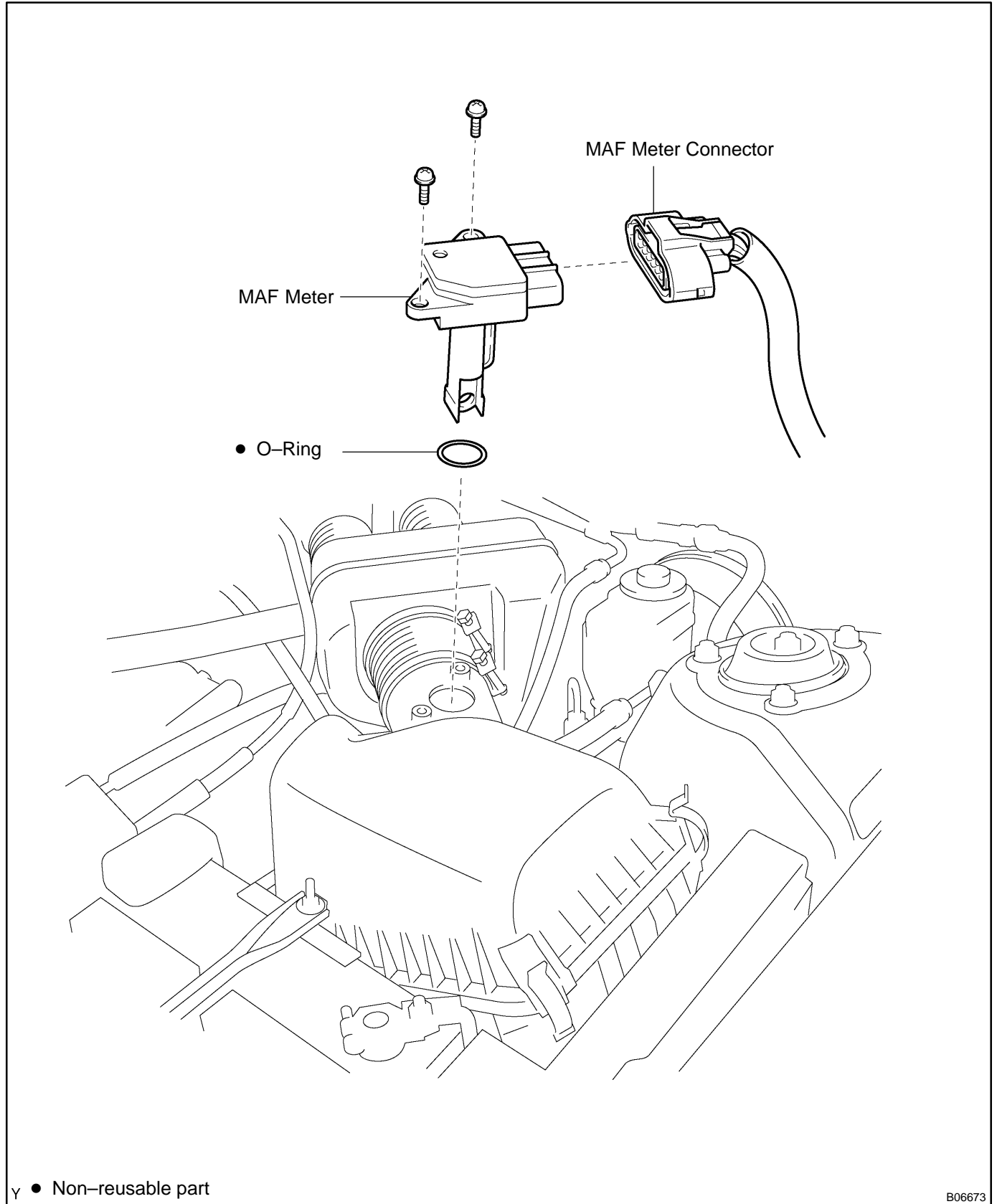

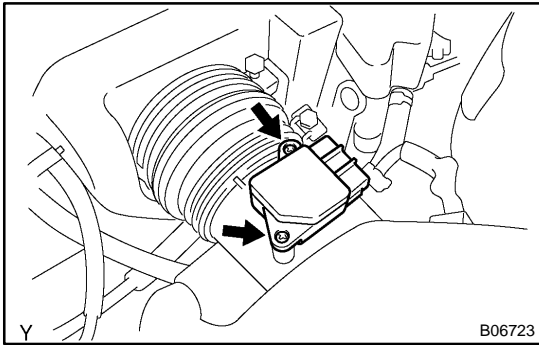

REMOVAL

REMOVE MAF METER

- (a) Disconnect the MAF meter connector.
- (b) Remove the 2 screws, MAF meter and O-ring.

HINT:

At the time of installation, please refer to the following items.
Install a new O-ring to the MAF meter.

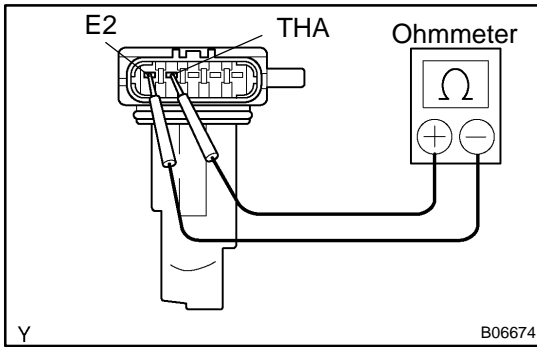

INSPECTION

1. INSPECT MAF METER RESISTANCE

Using an ohmmeter, measure the resistance between terminals THA and E2.

Resistance:

Terminals	Resistance	Temperature
THA - E2	13.6 - 18.4 kΩ	-20°C (-4°F)
THA - E2	2.21 - 2.69 kΩ	20°C (68°F)
THA - E2	0.49 - 0.67 kΩ	60°C (140°F)

If the resistance is not as specified, replace the MAF meter.

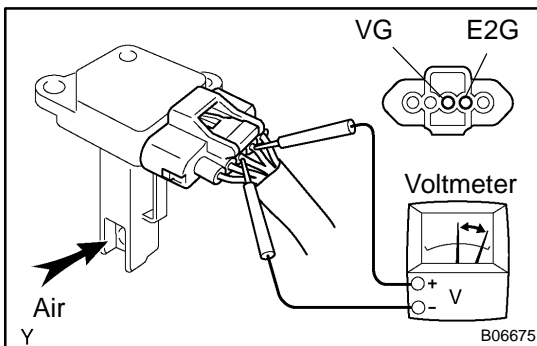

2. INSPECT MAF METER OPERATION

- Connect the MAF meter connector.
- Turn the ignition switch ON.
- Using a voltmeter, connect the positive (+) tester probe to terminal VG, and negative (-) tester probe to terminal E2G.
- Blow air into the MAF meter, and check that the voltage fluctuates.

If operation is not as specified, replace the MAF meter.

- Turn the ignition switch LOCK.
- Disconnect the MAF meter connector.

INSTALLATION

Installation is in the reverse order of removal (See page [SF-28](#)).

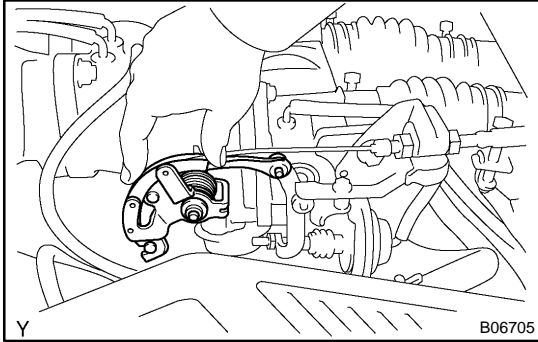

THROTTLE BODY ON-VEHICLE INSPECTION

SF061-02

1. INSPECT THROTTLE BODY

Check that the throttle linkage moves smoothly.

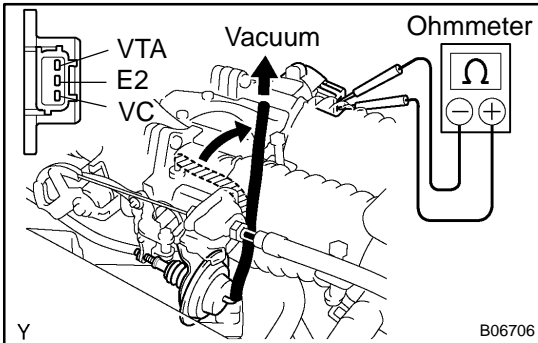

2. INSPECT THROTTLE POSITION SENSOR

- Disconnect the sensor connector.
- Disconnect the vacuum hose from the throttle body.
- Apply vacuum to the throttle opener.
- Using an ohmmeter, measure the resistance between each terminal.

Resistance:

Throttle valve condition	Between terminals	Resistance
Fully closed	VTA - E2	0.2 - 6.3 kΩ
Fully open	VTA - E2	2.0 - 10.2 kΩ
-	VC - E2	2.5 - 5.9 kΩ

- Reconnect the vacuum hose to the throttle body.

3. INSPECT THROTTLE OPENER

- Allow the engine to warm up to normal operating temperature.
- Check idle speed.

Idle speed: 700 ± 50 rpm

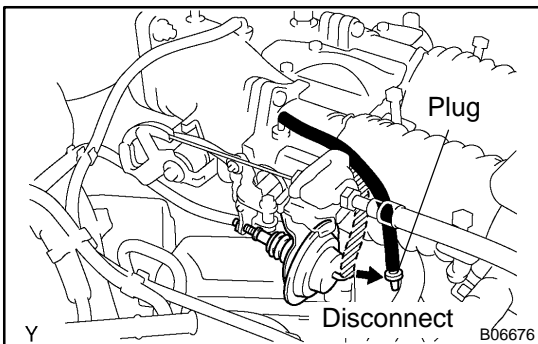

- Disconnect the vacuum hose from the throttle opener, and plug the hose end.
- Check the throttle opener setting speed.

Throttle opener setting speed: 1,100 - 1,700 rpm

If the throttle opener setting is not as specified, replace the throttle body.

- Stop the engine.
- Reconnect the vacuum hose to the throttle opener.
- Start the engine and check that the idle speed returns to the correct speed.

COMPONENTS

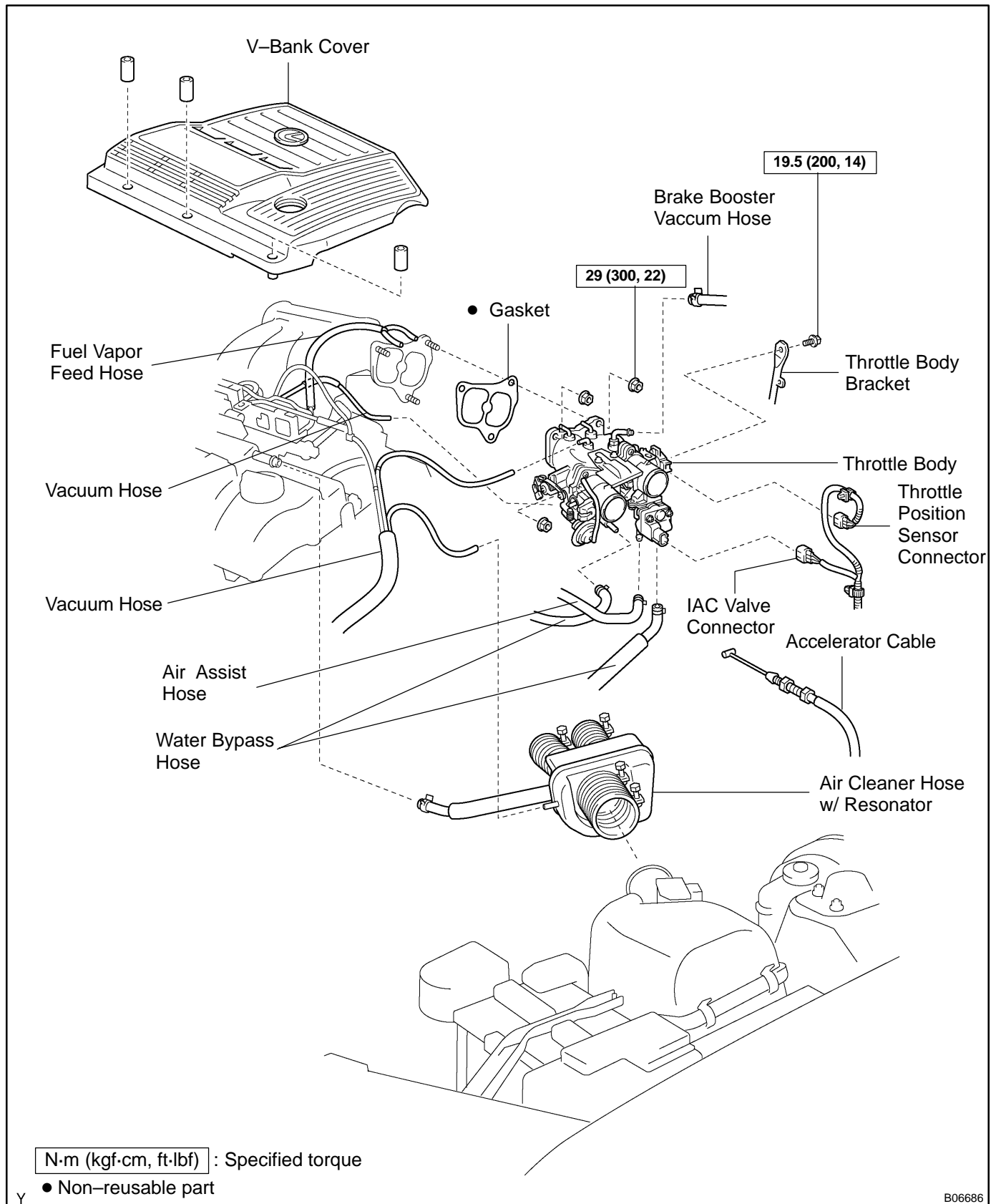

B06686

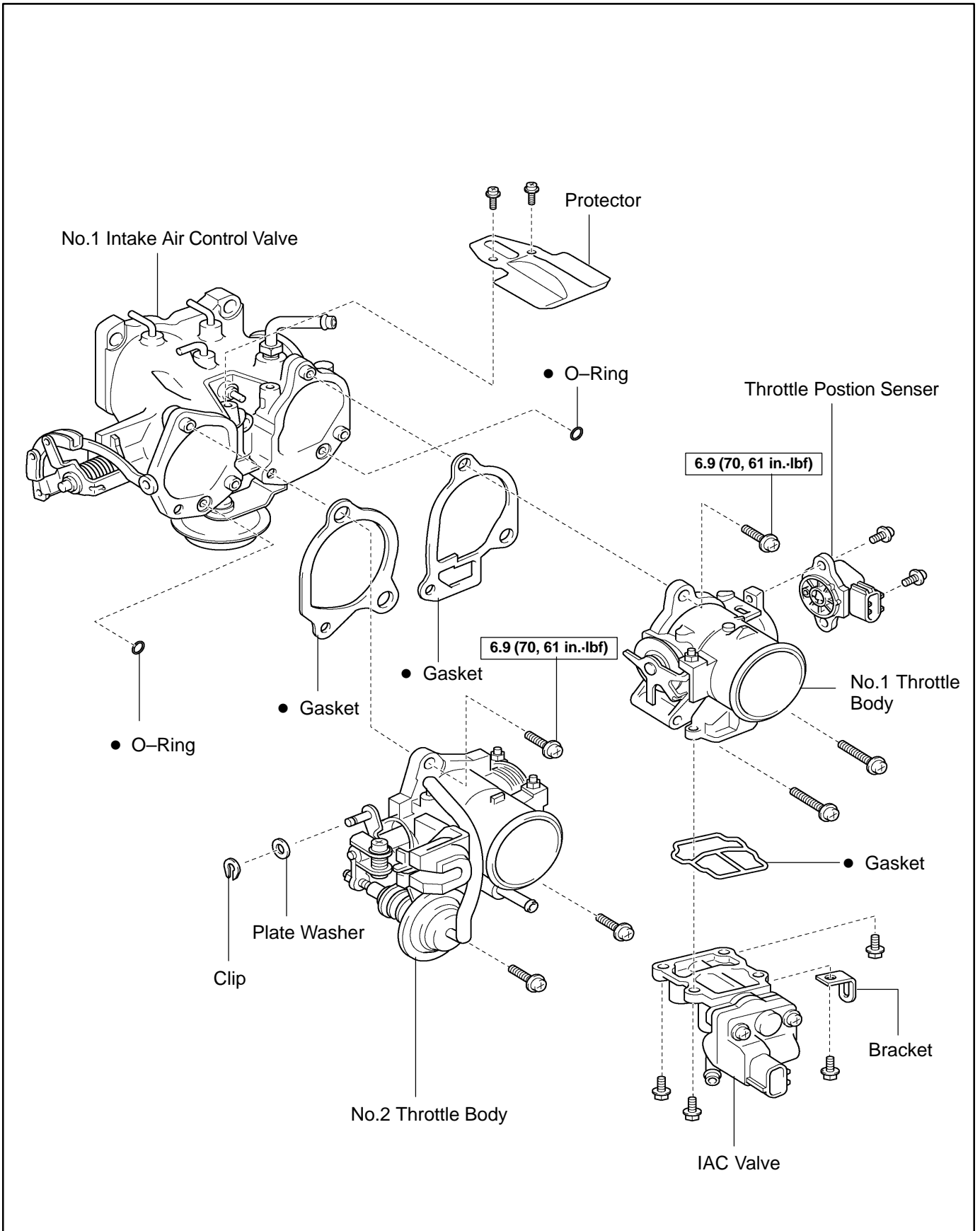

Y N·m (kgf·cm, ft·lbf) : Specified torque
 ● Non-reusable part

B06506

REMOVAL

1. DRAIN ENGINE COOLANT

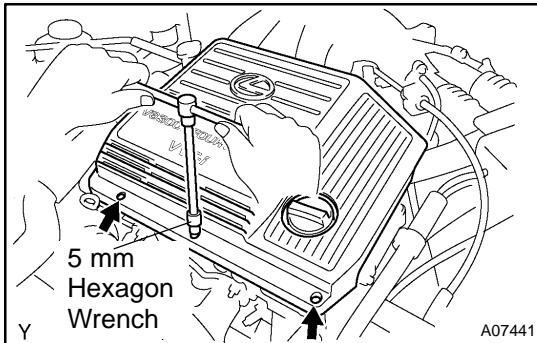

2. REMOVE V-BANK COVER

- Using a 5 mm hexagon wrench, remove the 3 cap nuts.
- Loosen the V-bank cover fastener counterclockwise.

HINT:

At the time of installation, please refer to the following items. Press down the V-bank cover fastener.

- Remove the V-bank cover.

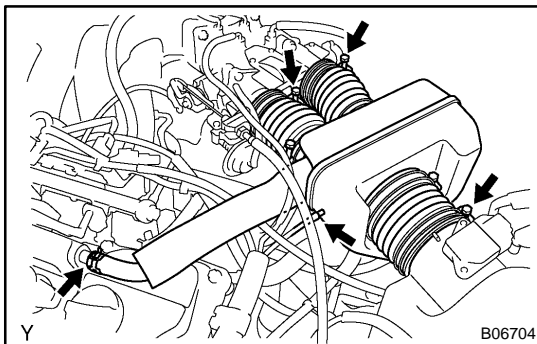

3. REMOVE AIR CLEANER HOSE WITH RESONATOR

- Disconnect the PCV hose.
- Disconnect the vacuum hose (from the VSV for the active engine control mount).
- Loosen the 3 hose clamps, and remove the air cleaner hose with the resonator.

4. DISCONNECT ACCELERATOR CABLE

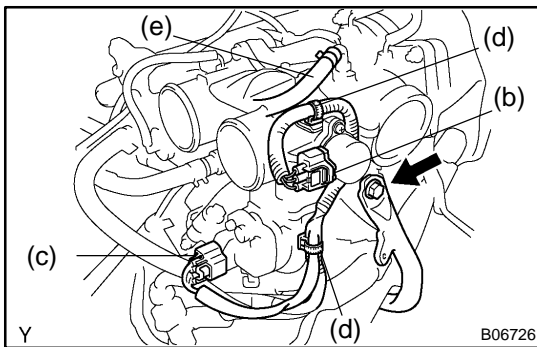

5. REMOVE THROTTLE BODY

- Remove the bolt holding the throttle body to the throttle body bracket.

Torque: 19.5 N·m (200 kgf·cm, 14 ft·lbf)

- Disconnect the throttle position sensor connector.
- Disconnect the IAC valve connector.
- Disconnect the 2 wire clamps.
- Disconnect the brake booster vacuum hose.

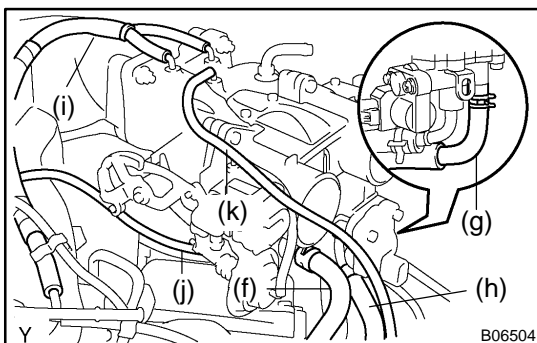

- Disconnect the water bypass hose (from the intake manifold).
- Disconnect the water bypass hose (from the water inlet housing).
- Disconnect the air assist hose.
- Disconnect the fuel vapor feed hose (from the emission control valve set).
- Disconnect the vacuum hose (from the No.1 ACIS VSV).
- Disconnect the vacuum hose (from the vacuum tank for the ACIS).

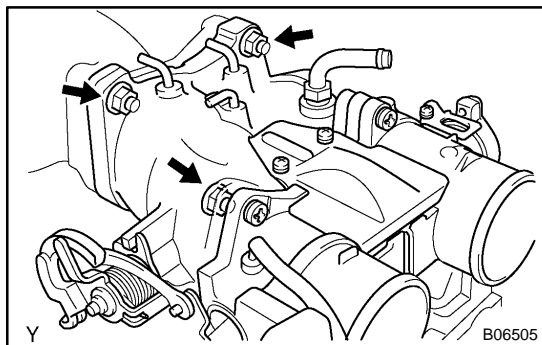

(I) Remove the 3 nuts, throttle body and gasket.

HINT:

At the time of installation, please refer to the following items.
Place a new gasket on the air intake chamber.

Torque: 29 N·m (300 kgf-cm, 22 ft-lbf)

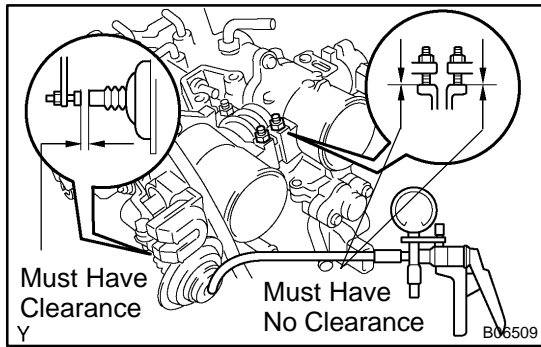

INSPECTION

NOTICE:

In case of changing, removing or installing the throttle body or IAC valve, must do this.

1. INSPECT THROTTLE BODY

- (a) Check that there is no clearance between each throttle stop screw and the throttle lever when applying the vacuum (53.3 kPa (400 mmHg, 15.7 in.Hg)) to the throttle opener using a MITYVAC (Hand-Held Vacuum Pump).

Standard: Must have no clearance

NOTICE:

As the throttle stop screw is precisely adjusted, so do not adjust it.

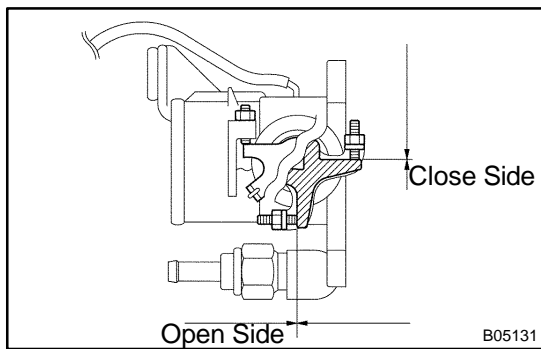

- (b) Under the condition of (1), check visually that there is a clearance between each adjust screw and the throttle lever on No.1 side.

Adjust screw	Reference value
Close side	About 0.13 mm (0.0051 in.)
Open side	About 0.22 mm (0.0087 in.)

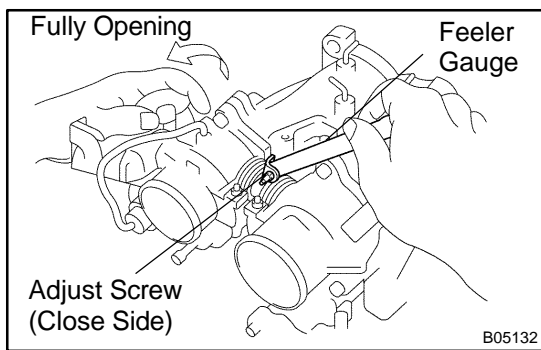

- (c) Measure the clearance between the adjust screw on the close side when fully opening the throttle lever on No.2 side by hand and the throttle lever on No.1 side with a feeler gauge.

Standard value: 0.25 – 0.45 mm (0.0098 – 0.0177 in.)

In case of being out of standard value, perform the adjustment of step 2.

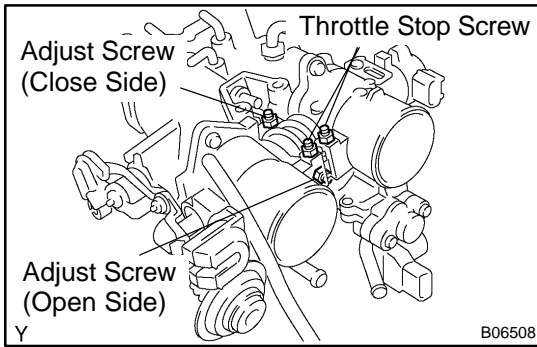

2. ADJUST THROTTLE BODY (BALANCE)

NOTICE:

Do not adjust the throttle stop screw and throttle opener.

- (a) Beforehand checking.
Recheck 1 – (a).
- (b) Adjustment of the adjust screw on the open side.
 - (1) Using a 2 mm hexagon wrench, loosen the lock nut and screw, make clearance between the screw tip and the throttle lever on No.1 side.
 - (2) Turn the screw to the screw torque direction gradually, and stop it at the position where to touch the lever at the very moment.

NOTICE:

If turning it too much to the torque direction, the No.1 lever goes off from the throttle stop screw causing the adjustment failure.

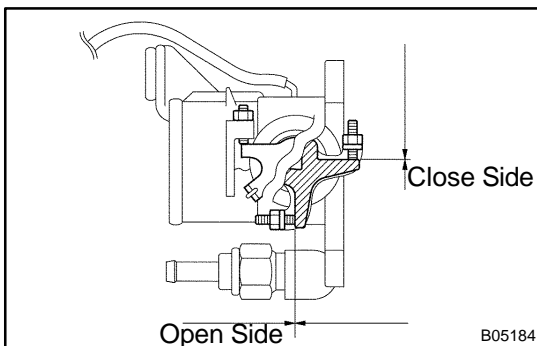

- (3) Turn it back from the position where it touches the lever to the screw losing direction.
- Standard: Turn it back by rotating 1/4**
- (4) Tighten the lock nut.
 - (c) Adjustment of the adjust screw on the close side.
 - (1) Loosen the lock nut and screw, and make clearance between the screw tip and the throttle lever on No.1 side.
 - (2) Turn the screw to the screw torque direction gradually, and stop it at the position where to touch the lever at the very moment.

NOTICE:

If turning it too much to the torque direction, the No.2 lever goes off from the throttle stop screw causing the adjustment failure.

- (3) Turn it back from the position where it touches the lever to the screw losing direction.
- Standard: Turn it back by rotating 1/2 – 3/4**
- (4) Tighten the lock nut.
 - (d) Completion checking.
Check 1 – (c).

REPLACEMENT

NOTICE:

- Do not give a shock to the throttle position sensor.
- Do not disassemble or adjust the throttle opener.

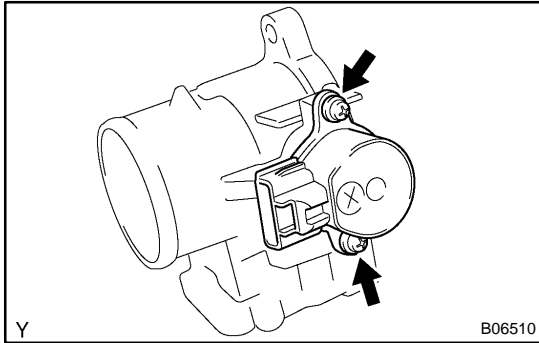

1. REPLACE THROTTLE POSITION SENSOR

- (a) Remove the 2 screws and throttle position sensor.

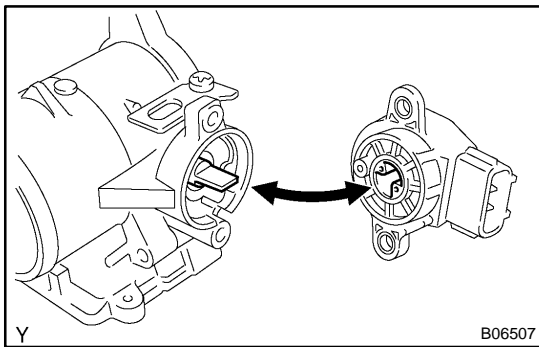

- (b) Reinstall a new throttle position sensor.
- (1) Check that the throttle valve is fully close.
 - (2) Insert the sensor to the throttle body with it turned counterclockwise by 30° to 60° against the fully-close valve position.
 - (3) By turning the sensor clockwise, tighten the 2 screws.

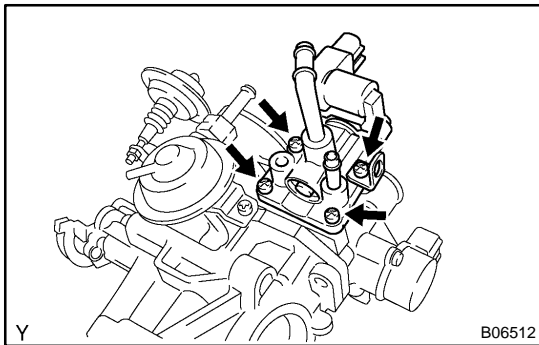

2. REPLACE IAC VALVE

- Remove the 4 screws, bracket, IAC valve and gasket.
- Place a new gasket on the No.1 throttle body.
- Reinstall a new IAC valve with the 4 screws and bracket.

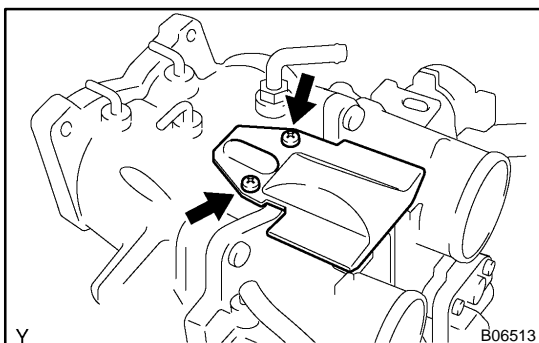

3. REPLACE THROTTLE BODIES

- (a) Remove the 2 screws and protector.

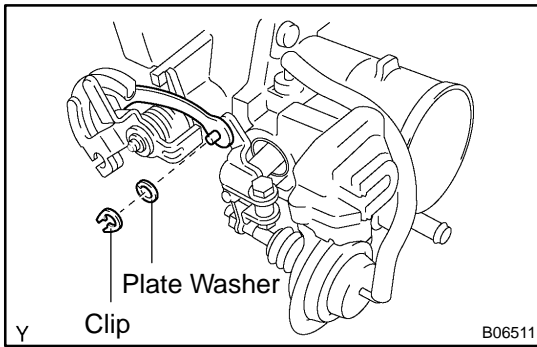

- (b) Remove the clip and plate washer, and disconnect the accelerator link.

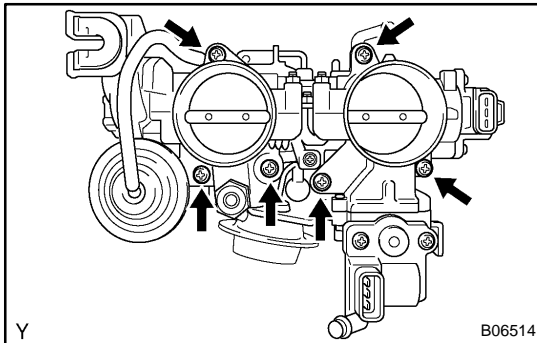

- (c) Remove the 6 screws, No.1 throttle body, No.2 throttle body and 2 gaskets from the No.1 intake air control valve.

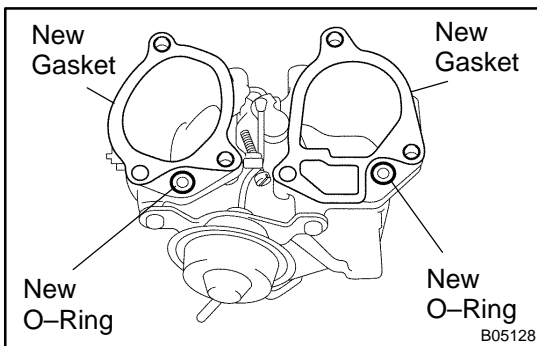

- (d) Place 2 new gaskets and 2 new O-rings as shown in the illustration.

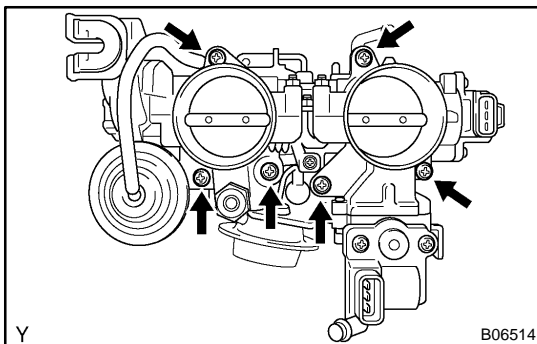

- (e) Reinstall a new No.1 throttle body and No.2 throttle body with the 6 screws.
Torque: 69 N·m (70 kgf·cm, 61 in.-lbf)

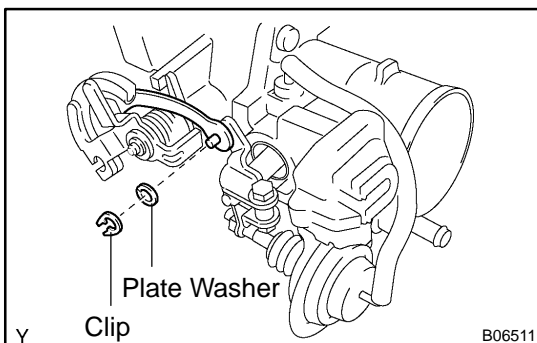

- (f) Reconnect the accelerator link with the plate washer and clip.
(g) Reinstall the protector with the 2 screws.

INSTALLATION

Installation is in the reverse order of removal (See page [SF-34](#)).

IDLE AIR CONTROL (IAC) VALVE ON-VEHICLE INSPECTION

SF02W-01

1. INSPECT IAC VALVE OPERATION

- (a) Initial conditions:
- Engine at normal operating temperature
 - Idle speed checked correctly
 - Transmission in neutral position
 - A/C switch OFF

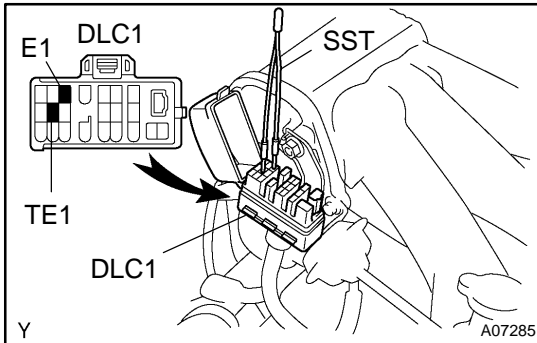

- (b) Using SST, connect terminals TE1 and E1 of the DLC1.

SST 09843-18020

- (c) After engine speed is kept at approx. 1,000 rpm for 5 seconds, check that it returns to idle speed.

If the engine speed operation is not as specified, check the IAC valve, wiring and ECM.

- (d) Remove the SST from the DLC1.

SST 09843-18020

2. INSPECT AIR ASSIST SYSTEM

- (a) Initial conditions:
- Engine at normal operating temperature
 - Idle speed checked correctly
 - Transmission in neutral position
 - A/C switch OFF

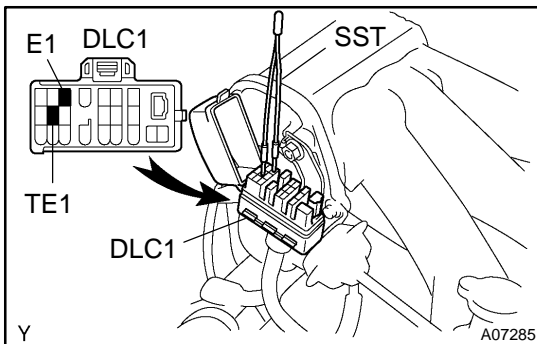

- (b) Using SST, connect terminals TE1 and E1 of the DLC1.

SST 09843-18020

- (c) After engine speed is kept at 900 – 1,300 rpm for 10 seconds, check that it returns to idle speed.

- (d) Stop the engine.

- (e) Remove the V-bank cover.

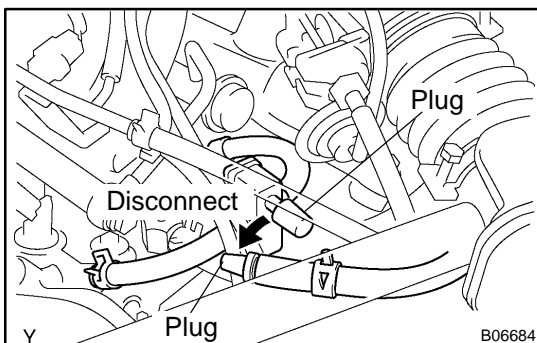

- (f) Disconnect the air assist hose from the air pipe, and block off the IAC valve exit and the entry to the pipe.

- (g) Start the engine and check that the idle speed reaches 500 rpm or below (the engine may stall).

If the idle does not reach 500 rpm or below, check for a leak between the air assist hoses, pipe and injectors.

- (h) Remove the SST from the DLC1.

SST 09843-18020

- (i) Reconnect the air assist hose to the air pipe.

- (j) Reinstall the V-bank cover.

COMPONENTS

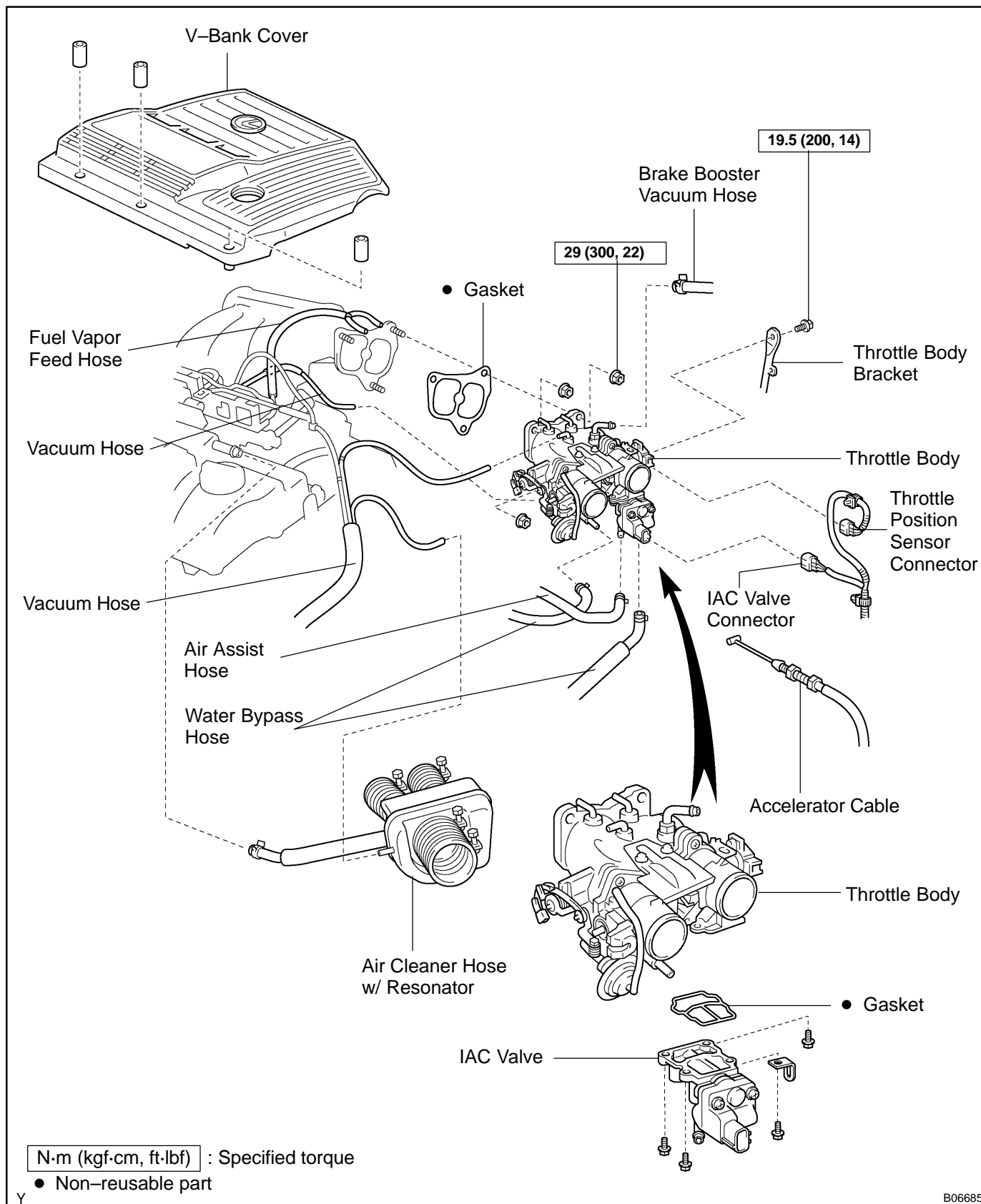

B06685

REMOVAL

1. REMOVE THROTTLE BODY (See page SF-34)

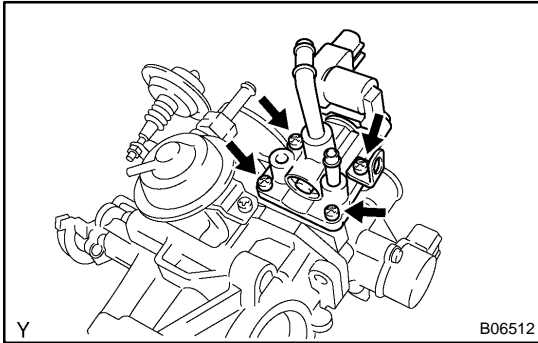

2. REMOVE IAC VALVE

Remove the 4 screws, bracket, IAC valve and gasket.

HINT:

At the time of installation, please refer to the following items.
Place a new gasket on the throttle body.

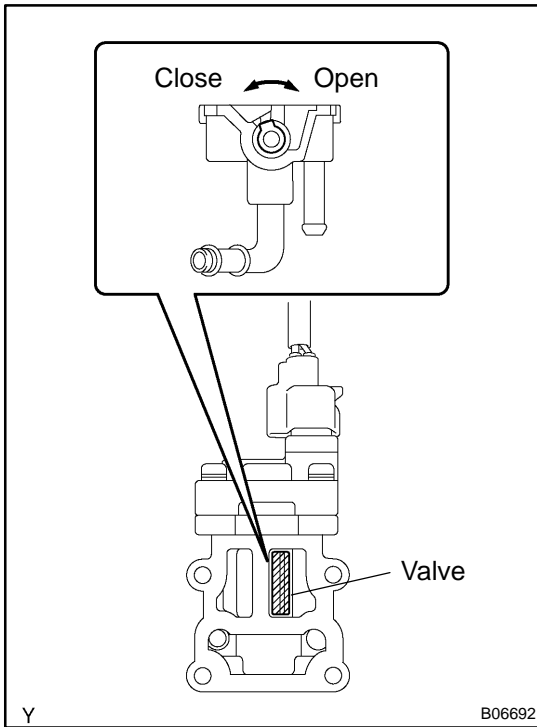

INSPECTION

INSPECT IAC VALVE OPERATION

- (a) Check that the IAC valve is halfly opened.
- (b) Connect the IAC valve connector to the IAC valve.
- (c) Turn the ignition switch ON.
- (d) Check that the IAC valve moves in 0.5 seconds by order of fully close, fully open and halfly open.

If operation is not as specified, replace the IAC valve.

- (e) Turn the ignition switch OFF.
- (f) Disconnect the IAC valve connector from the IAC valve.

INSTALLATION

Installation is in the reverse order of removal (See page [SF-43](#)).

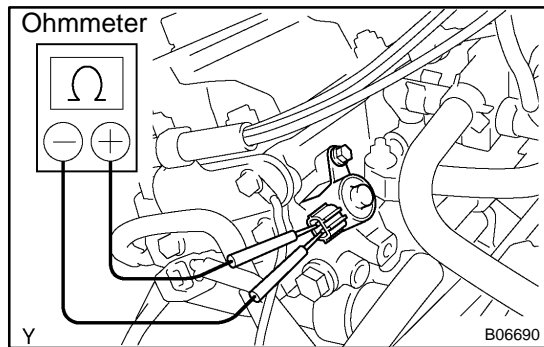

CAMSHAFT TIMING OIL CONTROL VALVE

SFOSL-03

ON-VEHICLE INSPECTION

INSPECT OIL CONTROL VALVE RESISTANCE

- (a) Remove the V-bank cover.
- (b) Disconnect the oil control valve connector.
- (c) Using an ohmmeter, measure the resistance between the terminals.

Resistance: 6.9 – 7.9 Ω at 20°C (68°F)

If the resistance is not as specified, replace the valve.

- (d) Reconnect the oil control valve connector.
- (e) Reinstall the V-bank cover.

COMPONENTS

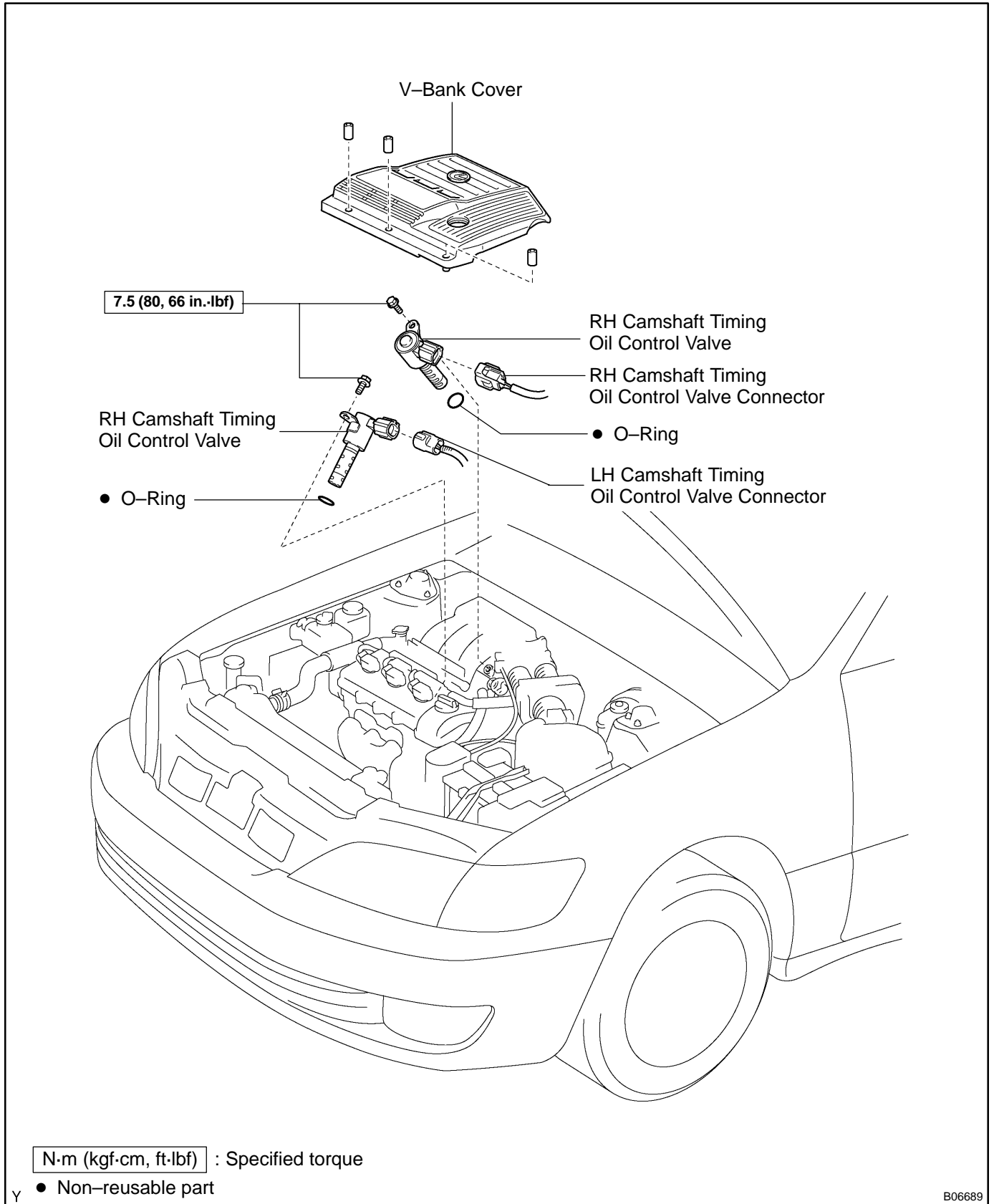

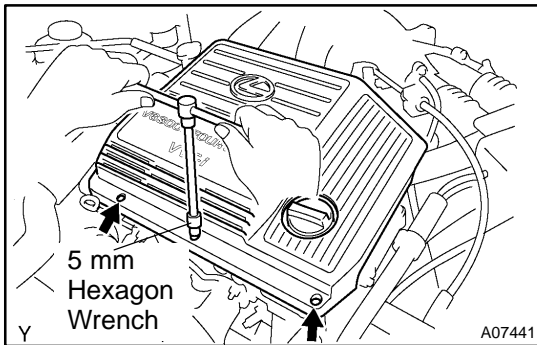

REMOVAL

1. REMOVE V-BANK COVER

- (a) Using a 5 mm hexagon wrench, remove the 3 cap nuts.
- (b) Loosen the V-bank cover fastener counterclockwise.

HINT:

At the time of installation, please refer to the following items.
Press down the V-bank cover fastener.

- (c) Remove the V-bank cover.

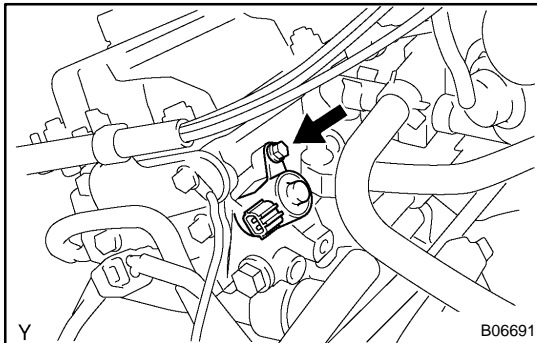

2. REMOVE CAMSHAFT TIMING OIL CONTROL VALVES

- (a) Disconnect the 2 camshaft oil control valve connectors.
- (b) Remove the bolt, camshaft oil control valve and O-ring. Remove the 2 camshaft oil control valves.

Torque: 7.5 N·m (80 kgf-cm, 66 in.-lbf)

- (c) Remove the O-ring from the each camshaft oil control valve.

HINT:

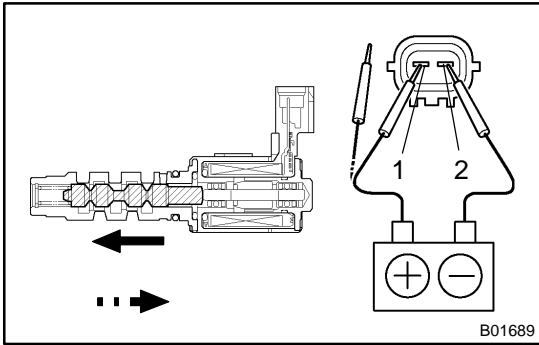

At the time of installation, please refer to the following items.
Use a new O-ring.



INSPECTION

INSPECT CAMSHAFT OIL CONTROL VALVE OPERATION

Connect the positive (+) lead from the battery to terminal 1 and negative (-) lead to terminal 2, and check the movement of the valve.

Battery positive voltage is applied	Valve moves in  direction
Battery positive voltage is cut off	Valve moves in  direction

If operation is not as specified, replace the valve.

INSTALLATION

Installation is in the reverse order of removal. (See page [SF-48](#))

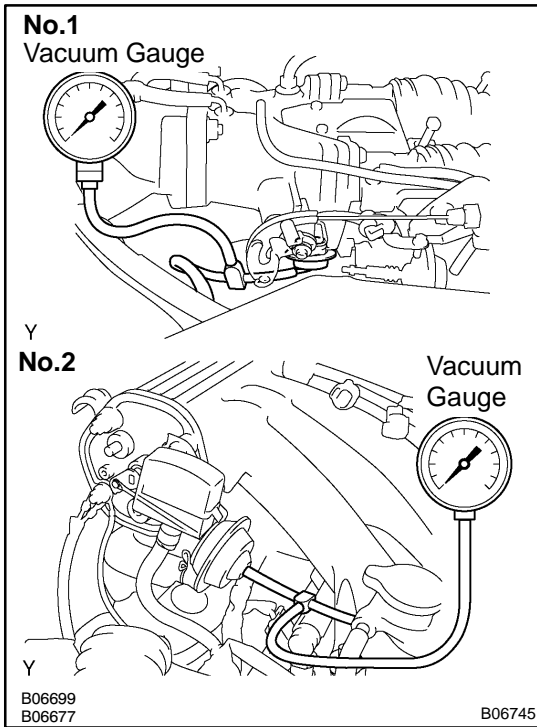

ACOUSTIC CONTROL INDUCTION SYSTEM (ACIS)

SF06B-03

ON-VEHICLE INSPECTION

INSPECT INTAKE AIR CONTROL VALVE

- (a) Using a 3-way connector, connect vacuum gauge to the actuator hose.
- (b) Start the engine.
- (c) While the engine is idling, check that the vacuum gauge needle does not move.

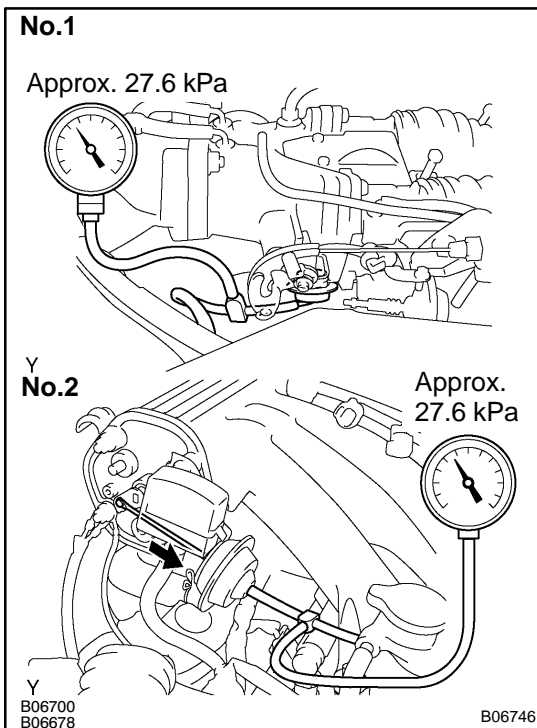

- (d) Rapidly depress the accelerator pedal to fully open position and check that the vacuum gauge needle momentarily fluctuates up to approx. 26.7 kPa (200 mmHg, 7.9 in.Hg). (The actuator rod is pulled out.)

COMPONENTS

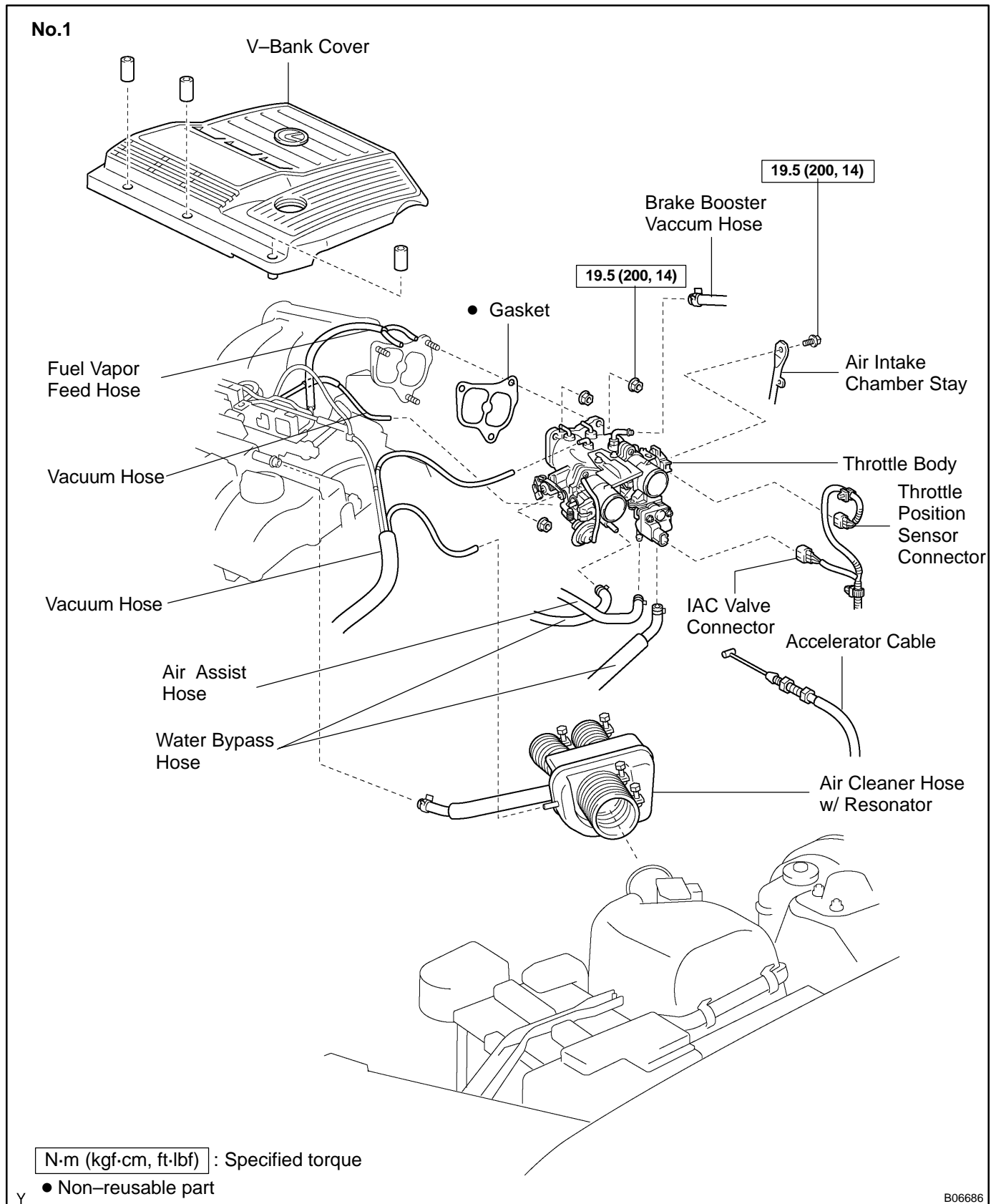

No.1

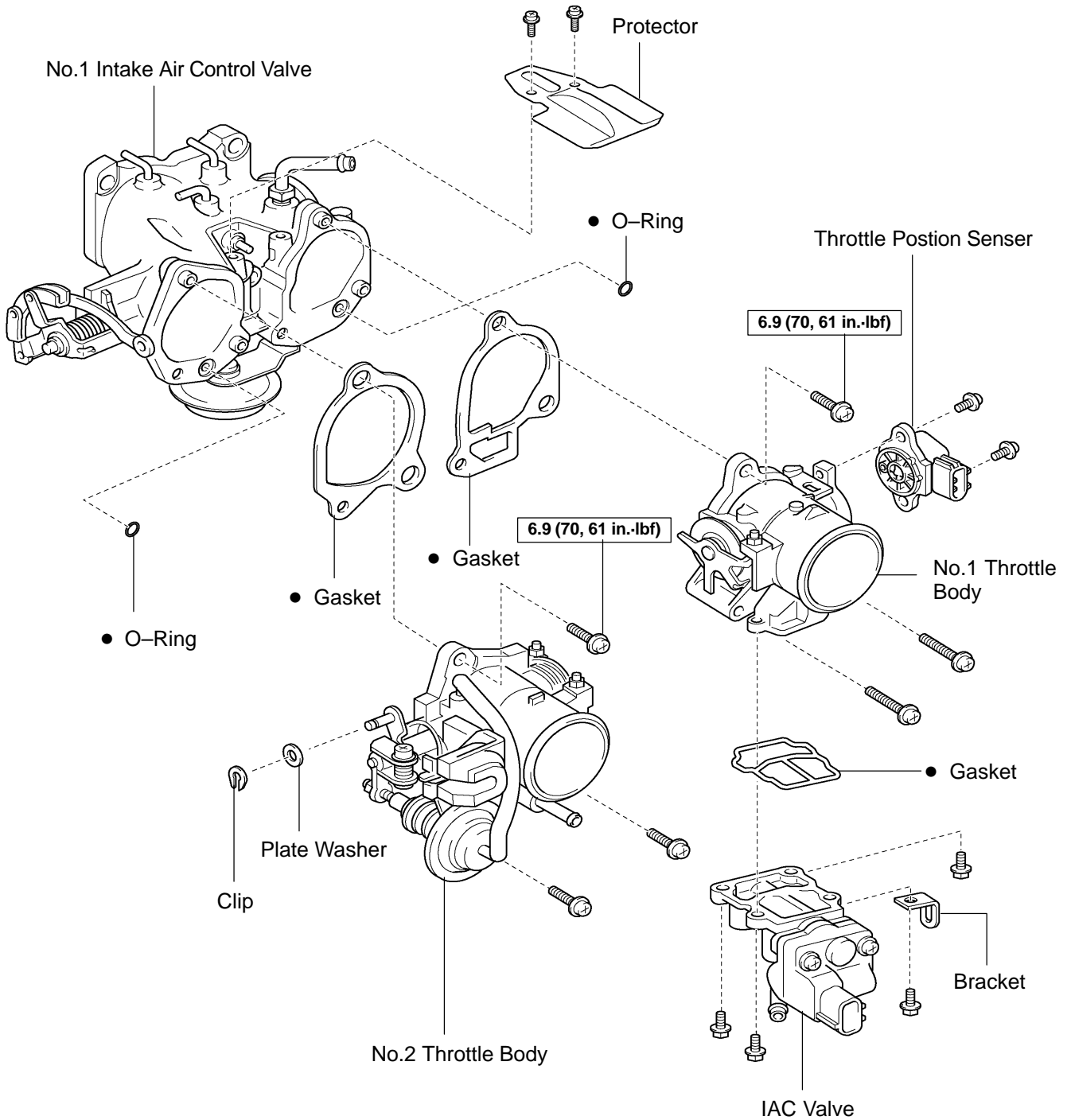

Y N·m (kgf·cm, ft·lbf) : Specified torque
 ● Non-reusable part

B06506

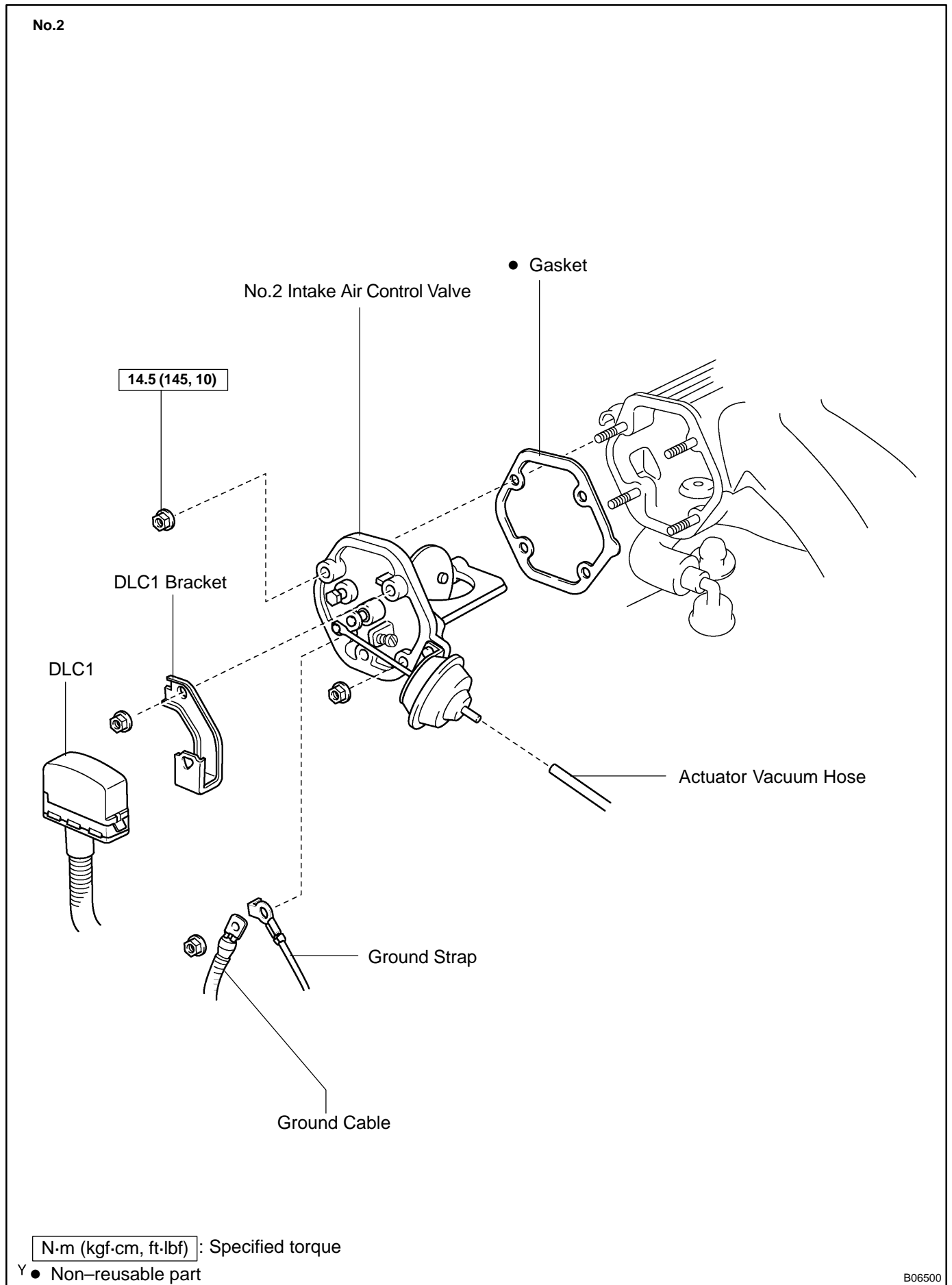

REMOVAL

1. REMOVE NO.1 INTAKE AIR CONTROL VALVE (See pages SF-34 and SF-38)

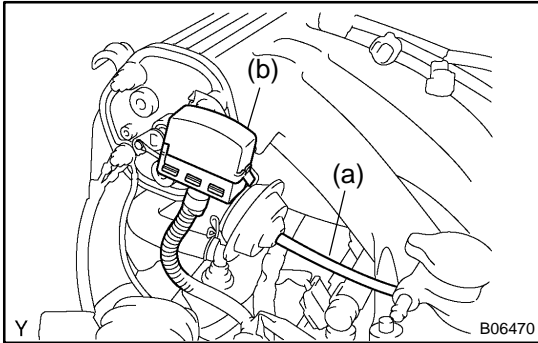

2. REMOVE NO.2 INTAKE AIR CONTROL VALVE

- (a) Disconnect the actuator vacuum hose.
- (b) Disconnect the DLC1 from the DLC1 bracket.

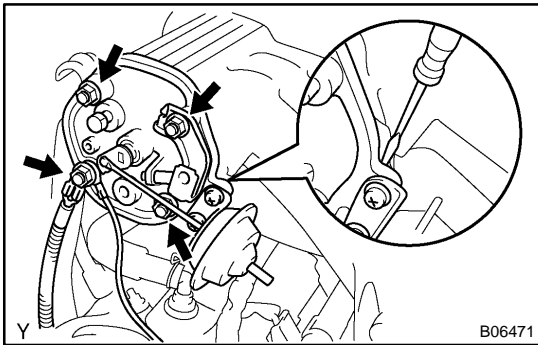

- (c) Remove the intake air control valve.
 - (1) Remove the 4 nuts and DLC1 bracket, and disconnect the ground strap and cable.
 - (2) Remove the intake air control valve by prying a screwdriver between the intake air control valve and air intake chamber.
 - (3) Remove the gasket.

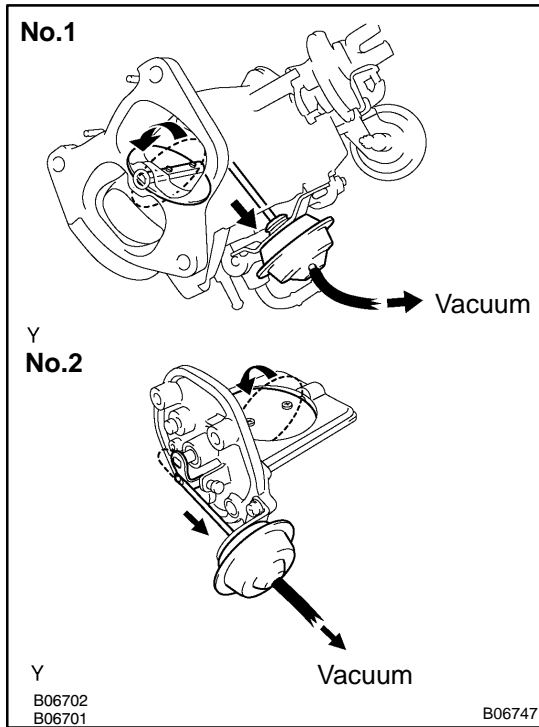

INSPECTION

1. INSPECT INTAKE AIR CONTROL VALVE

- With 26.7 kPa (200 mmHg, 7.9 in.Hg) of vacuum applied to the actuator, check that the actuator rod moves.
- One minute after applying the vacuum in (a), check that the actuator rod does not return.

If the operation is not as specified, replace the intake air control valve.

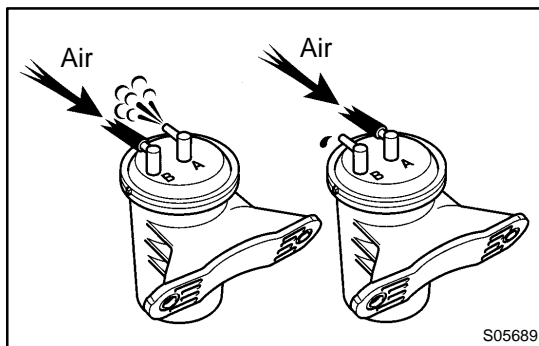

2. INSPECT VACUUM TANK

LOCATION: The LH side member under the battery tray.

- Check that air flows from port B to port A.
- Check that air does not flow from port A to port B.

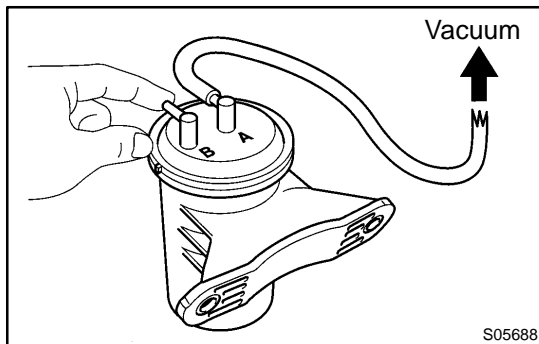

- Plug port B with your finger, and apply 26.7 kPa (200 mmHg, 7.9 in.Hg) of vacuum to port A, and check that there is no change in vacuum after one minute.

If the operation is not as specified, replace the vacuum tank.

3. INSPECT VSV (See page SF-65)

INSTALLATION

1. **INSTALL NO.1 INTAKE AIR CONTROL VALVE**
(See pages SF-38 and SF-40)

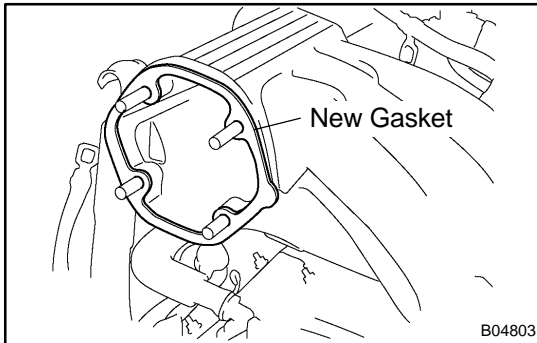

2. **INSTALL NO.2 INTAKE AIR CONTROL VALVE**

- (a) Install the No.2 intake air control valve.
 - (1) Install a new gasket to the air intake chamber.

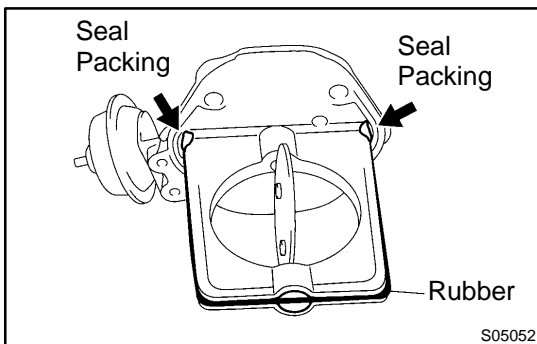

- (2) Apply a light coat of engine oil to the rubber portions.
- (3) Apply seal packing to the positions of the intake air control valve shown in the illustration.

Seal packing: Part No. 08826-00080 or equivalent

- (4) Install the intake air control valve, DLC1 bracket, ground strap and cable with the 4 nuts.

Torque: 14.5 N·m (145 kgf-cm, 10 ft-lbf)

- (b) Connect the DLC1.
- (c) Connect the actuator vacuum hose.

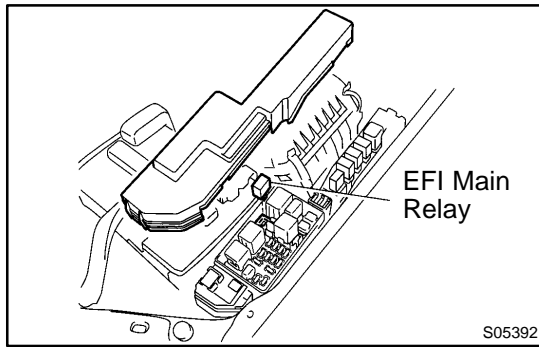

EFI MAIN RELAY INSPECTION

SF06G-07

1. REMOVE RELAY BOX COVER
2. REMOVE EFI MAIN RELAY (Marking: EFI)

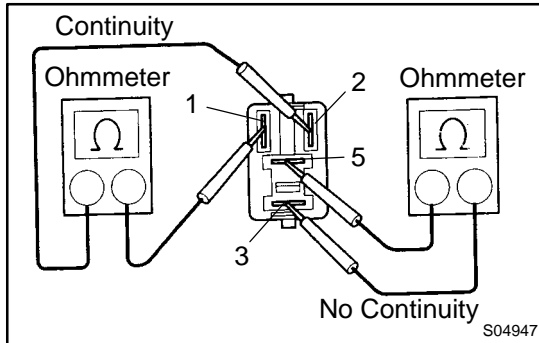

3. INSPECT EFI MAIN RELAY CONTINUITY

- (a) Using an ohmmeter, check that there is continuity between terminals 1 and 2.

If there is no continuity, replace the relay.

- (b) Check that there is no continuity between terminals 3 and 5.

If there is continuity, replace the relay.

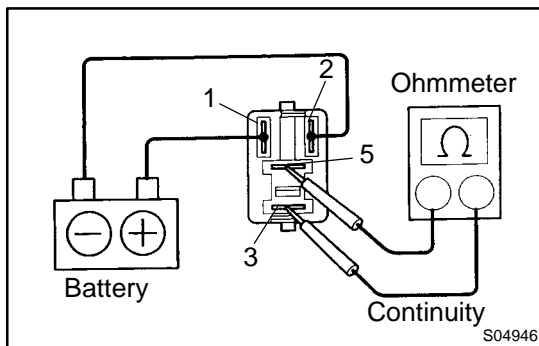

4. INSPECT EFI MAIN RELAY OPERATION

- (a) Apply battery voltage across terminals 1 and 2.

- (b) Using an ohmmeter, check that there is continuity between terminals 3 and 5.

If there is no continuity, replace the relay.

5. REINSTALL EFI MAIN RELAY
6. REINSTALL RELAY BOX COVER

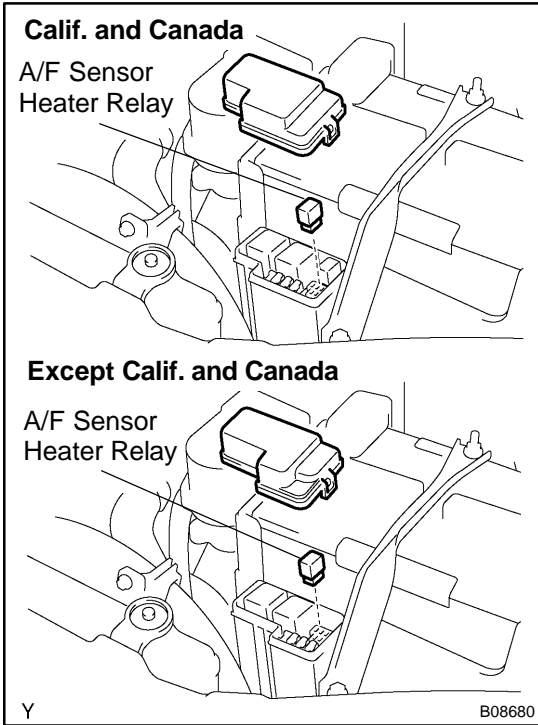

A/F SENSOR HEATER RELAY INSPECTION

SF14I-01

1. REMOVE RELAY BOX COVER
2. REMOVE A/F SENSOR HEATER RELAY (Marking: A/F HTR)

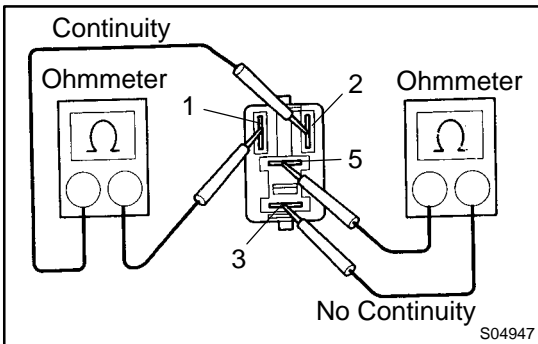

3. INSPECT A/F SENSOR HEATER RELAY CONTINUITY
 - (a) Using an ohmmeter, check that there is continuity between terminals 1 and 2.
 - If there is no continuity, replace the relay.
 - (b) Check that there is no continuity between terminals 3 and 5.
 - If there is continuity, replace the relay.

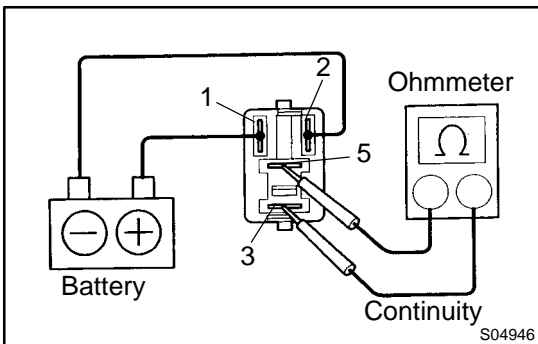

4. INSPECT A/F SENSOR HEATER RELAY OPERATION
 - (a) Apply battery voltage across terminals 1 and 2.
 - (b) Using an ohmmeter, check that there is continuity between terminals 3 and 5.
 - If there is no continuity, replace the relay.
5. REINSTALL A/F SENSOR HEATER RELAY
6. REINSTALL RELAY BOX COVER

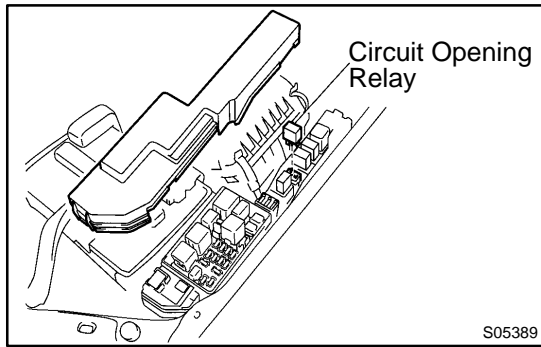

CIRCUIT OPENING RELAY INSPECTION

SF06H-05

1. REMOVE RELAY BOX COVER
2. REMOVE CIRCUIT OPENING RELAY
(Marking: CIR OPN)

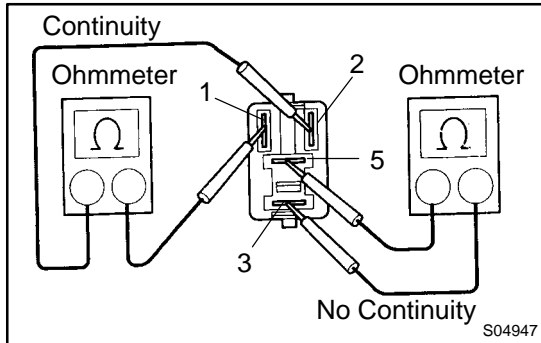

3. **INSPECT CIRCUIT OPENING RELAY CONTINUITY**
 - (a) Using an ohmmeter, check that there is continuity between terminals 1 and 2.

If there is no continuity, replace the relay.

 - (b) Check that there is no continuity between terminals 3 and 5.

If there is continuity, replace the relay.

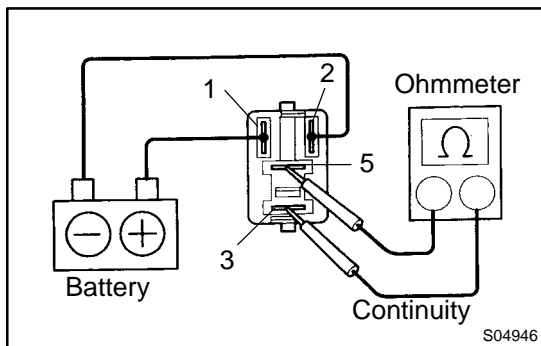

4. **INSPECT CIRCUIT OPENING RELAY OPERATION**
 - (a) Apply battery voltage across terminals 1 and 2.
 - (b) Using an ohmmeter, check that there is continuity between terminals 3 and 5.

If there is no continuity, replace the relay.
5. **REINSTALL CIRCUIT OPENING RELAY**
6. **REINSTALL RELAY BOX COVER**

VSV FOR EVAPORATIVE EMISSION (EVAP) COMPONENTS

SF06K-02

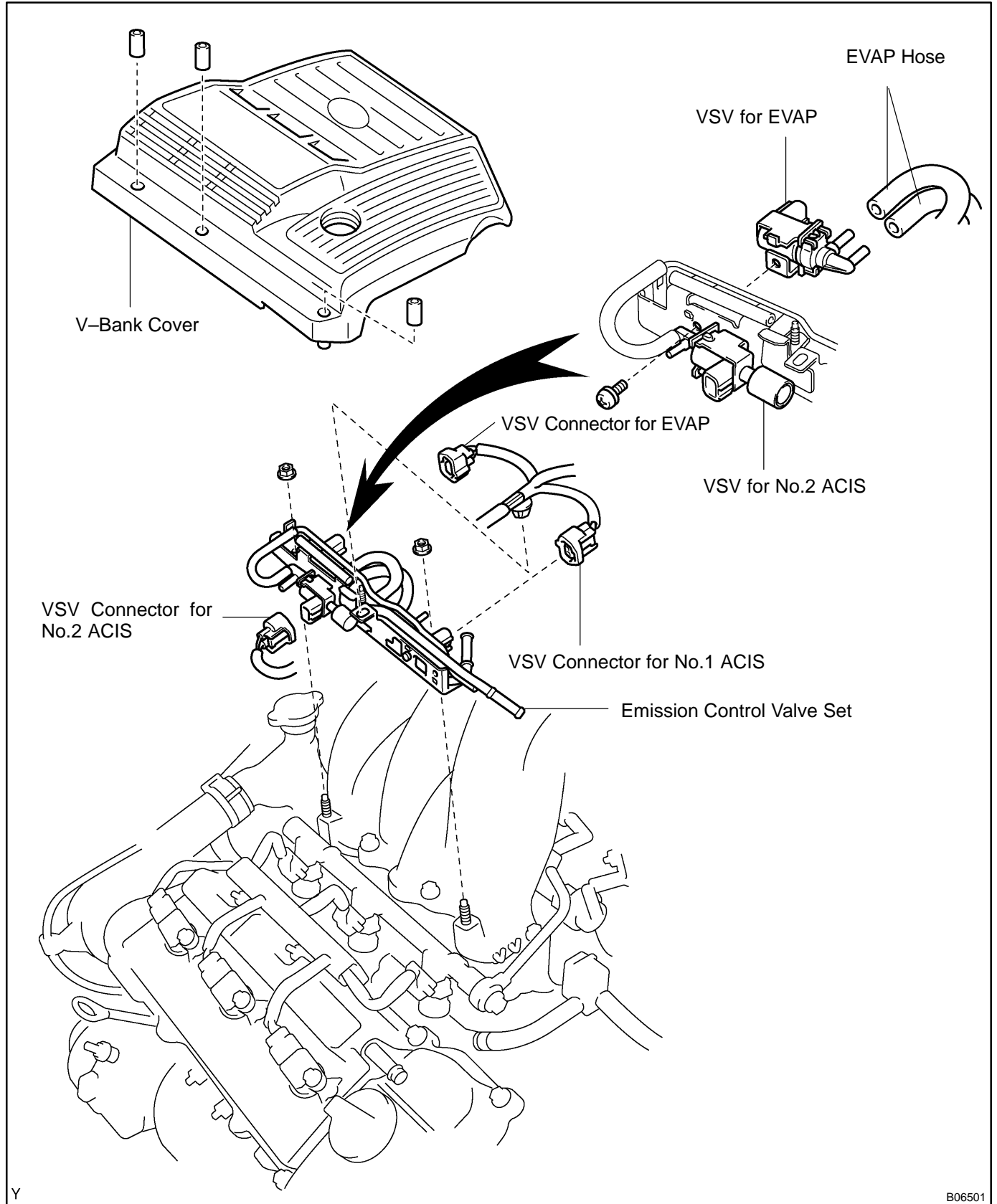

INSPECTION

1. REMOVE V-BANK COVER AND EMISSION CONTROL VALVE SET

2. REMOVE VSV

- (a) Disconnect the 2 EVAP hoses from the VSV.
- (b) Remove the screw and VSV.

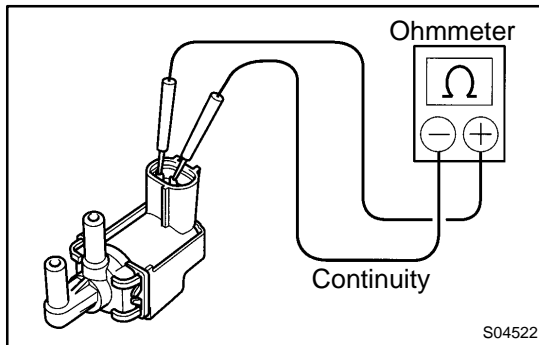

3. INSPECT VSV FOR OPEN CIRCUIT

Using an ohmmeter, check that there is continuity between the terminals.

Resistance: 27 – 33 Ω at 20°C (68°F)

If there is no continuity, replace the VSV.

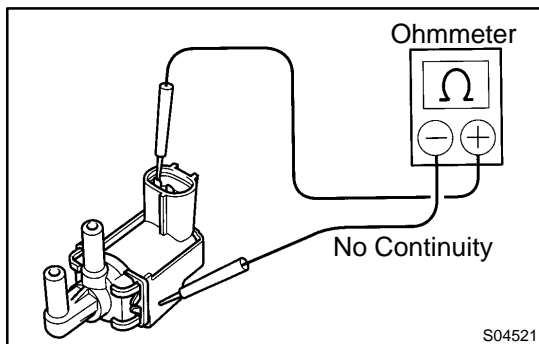

4. INSPECT VSV FOR GROUND

Using an ohmmeter, check that there is no continuity between each terminal and the body.

If there is continuity, replace the VSV.

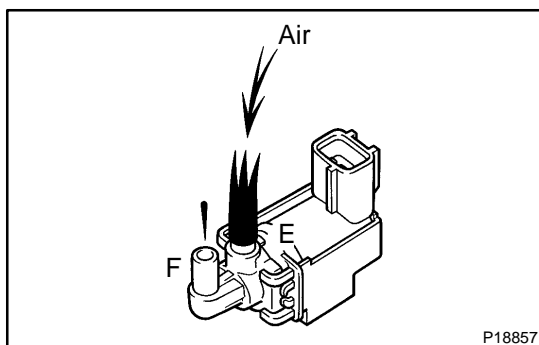

5. INSPECT VSV OPERATION

- (a) Check that air flows with difficulty from port E to port F.

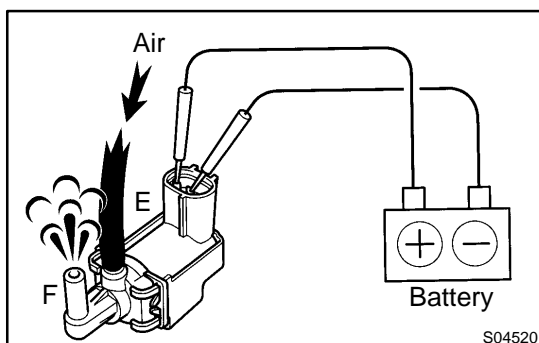

- (b) Apply battery voltage across the terminals.

- (c) Check that air flows from port E to port F.

If operation is not as specified, replace the VSV.

6. REINSTALL VSV

- (a) Install the VSV with the screw.

- (b) Connect the 2 EVAP hoses to the VSV.

7. REINSTALL EMISSION CONTROL VALVE SET

8. REINSTALL V-BANK COVER

VSV FOR ACOUSTIC CONTROL INDUCTION SYSTEM (ACIS) COMPONENTS

SF100-01

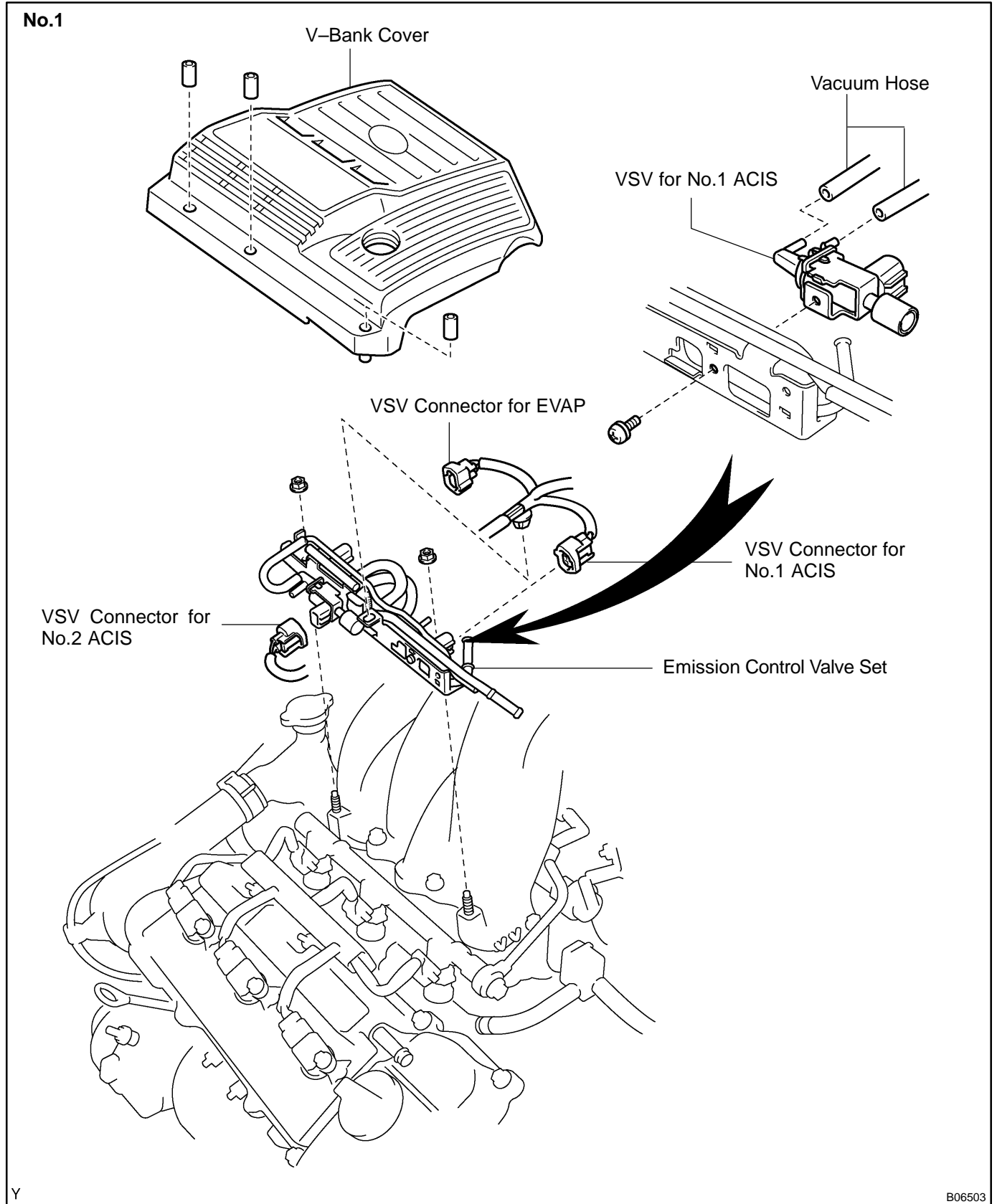

No.2

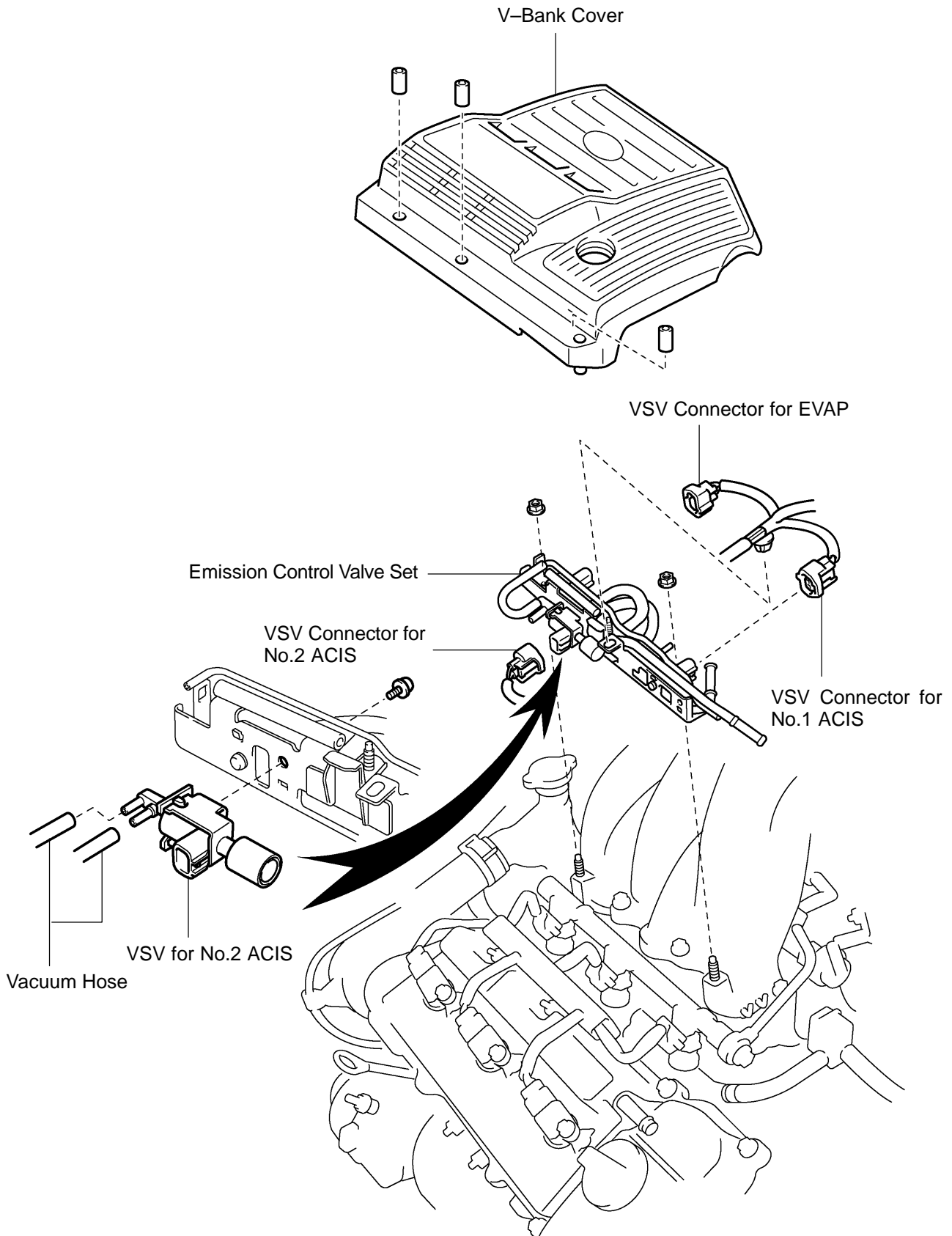

Y

B06502

INSPECTION

1. REMOVE V-BANK COVER, AND EMISSION CONTROL VALVE SET
2. REMOVE VSV
 - (a) Disconnect the 2 vacuum hoses from the VSV.
 - (b) Remove the screw and VSV.

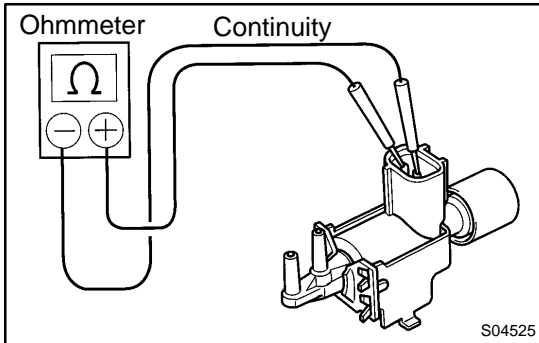

3. INSPECT VSV FOR OPEN CIRCUIT

Using an ohmmeter, check that there is continuity between each terminals.

Resistance: 33 – 39 Ω at 20°C (68°F)

If there is no continuity, replace the VSV.

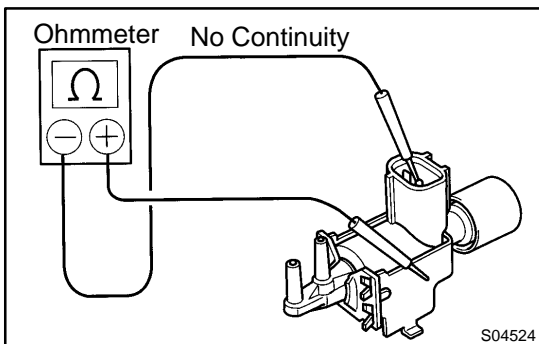

4. INSPECT VSV FOR GROUND

Using an ohmmeter, check that there is no continuity between each terminal and the body.

If there is continuity, replace the VSV.

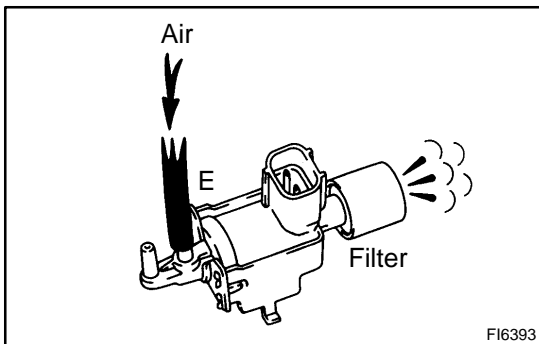

5. INSPECT VSV OPERATION

- (a) Check that air flows from port E to the filter.

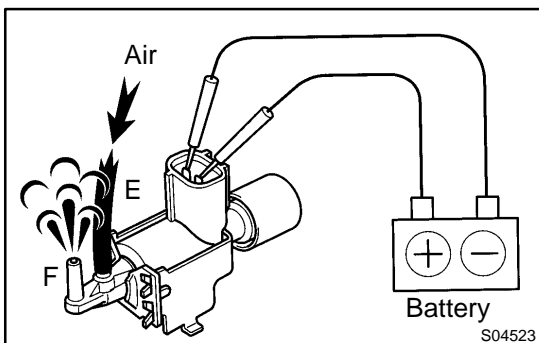

- (b) Apply battery voltage across the terminals.

- (c) Check that air flows from port E to port F.

If operation is not as specified, replace the VSV.

6. REINSTALL VSV

- (a) Install the VSV with the screw.
- (b) Connect the 2 vacuum to the VSV.

7. REINSTALL EMISSION CONTROL VALVE SET

8. REINSTALL V-BANK COVER

VSV FOR CANISTER CLOSED VALVE (CCV) COMPONENTS

SF14E-01

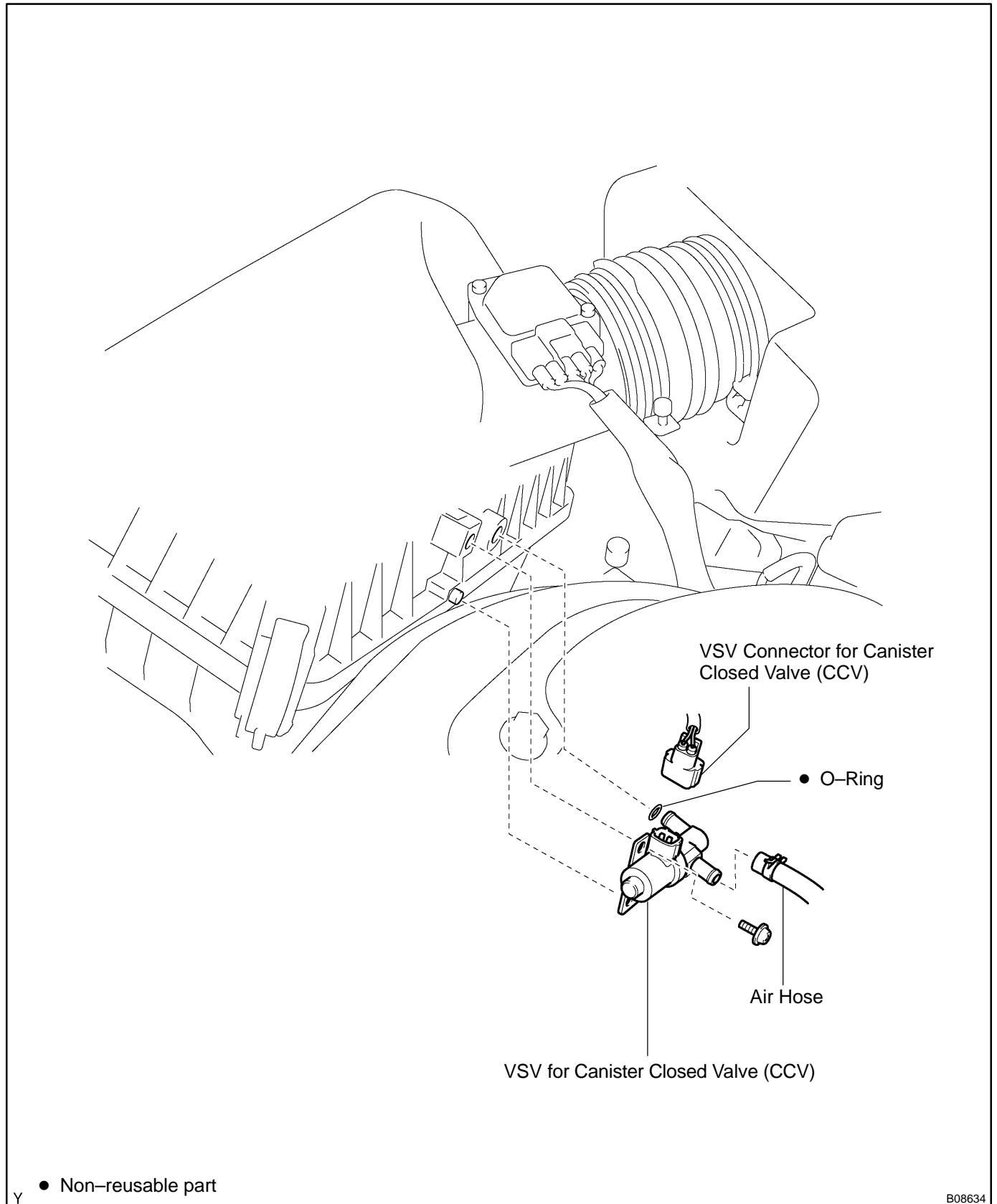

INSPECTION

1. REMOVE VSV

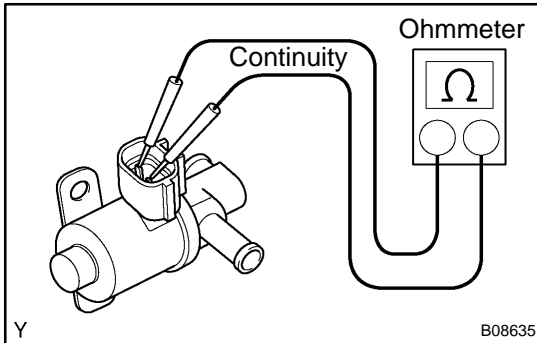

2. INSPECT VSV FOR OPEN CIRCUIT

Using an ohmmeter, check that there is continuity between the terminals.

Resistance:

At 20°C (68°F)	25 – 30 Ω
At 120°C (248°F)	33 – 42 Ω

If there is no continuity, replace the VSV.

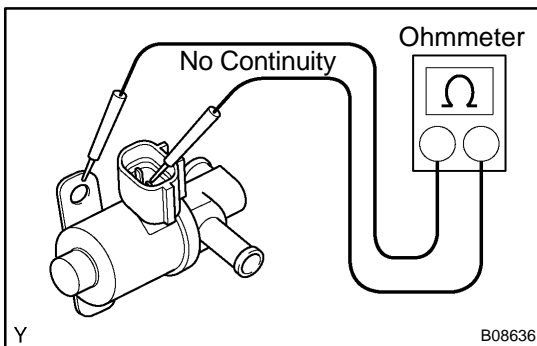

3. INSPECT VSV FOR GROUND

Using an ohmmeter, check that there is no continuity between each terminal and the body.

If there is continuity, replace the VSV.

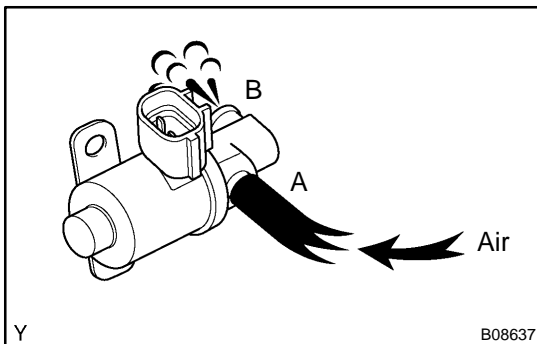

4. INSPECT VSV OPERATION

(a) Check that air flows from ports A to B.

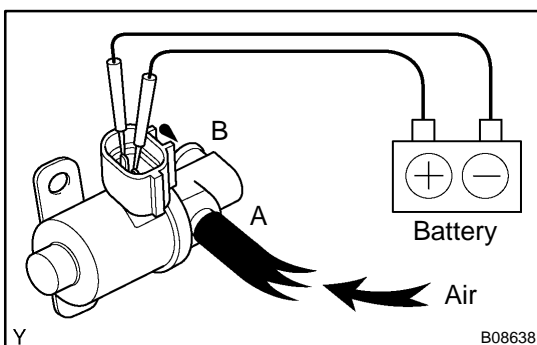

(b) Apply battery positive voltage across the terminals.

(c) Check that air does not flow from ports A to B.

If operation is not as specified, replace the VSV.

5. REINSTALL VSV

VSV FOR PRESSURE SWITCHING VALVE COMPONENTS

SF14G-01

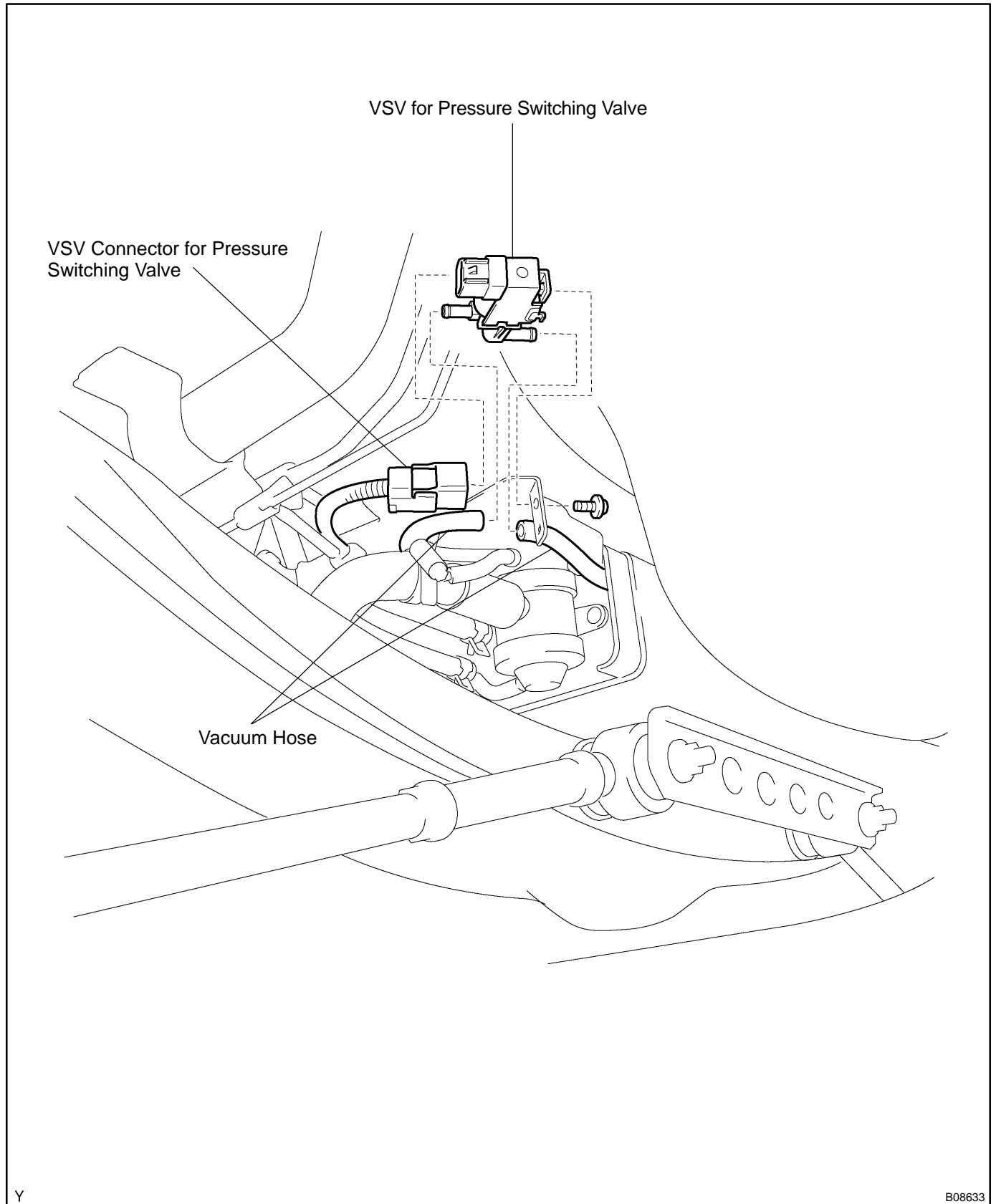

INSPECTION

1. REMOVE VSV

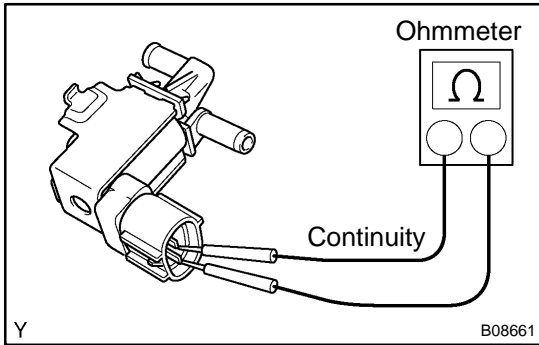

2. INSPECT VSV FOR OPEN CIRCUIT

Using an ohmmeter, check that there is continuity between the terminals.

Resistance:

At 20°C (68°F)	37 – 44 Ω
At 120°C (248°F)	51 – 62 Ω

If there is no continuity, replace the VSV.

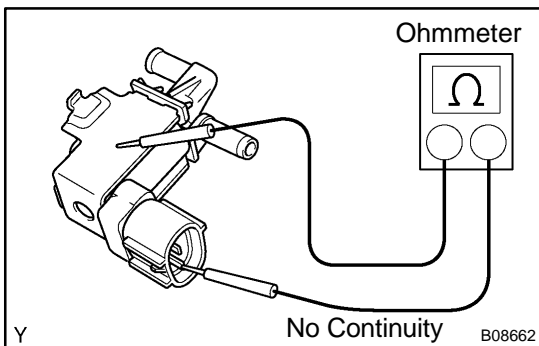

3. INSPECT VSV FOR GROUND

Using an ohmmeter, check that there is no continuity between each terminal and the body.

If there is continuity, replace the VSV.

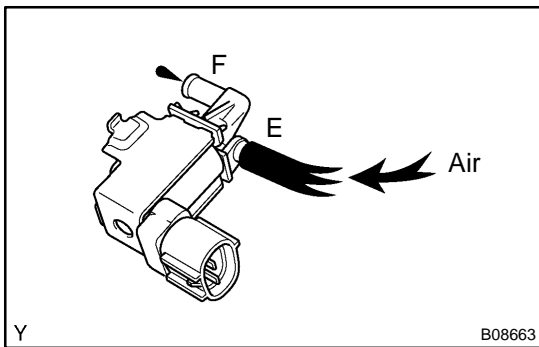

4. INSPECT VSV OPERATION

(a) Check that air does not flow from ports E to F.

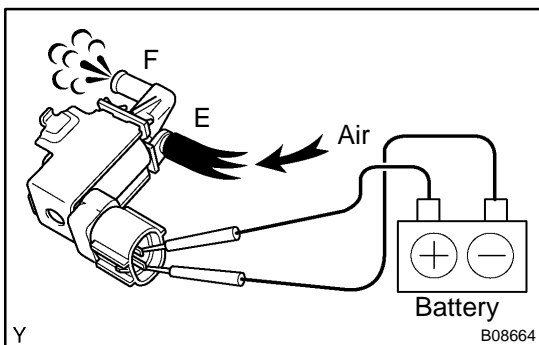

(b) Apply battery positive voltage across the terminals.

(c) Check that air flows from ports E to F.

If operation is not as specified, replace the VSV.

5. REINSTALL VSV

ENGINE COOLANT TEMPERATURE (ECT) SENSOR INSPECTION

SF06Q-03

1. DRAIN ENGINE COOLANT

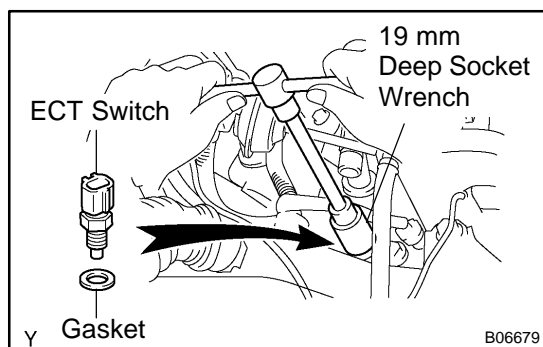

2. REMOVE ECT SENSOR

- Disconnect the ECT sensor connector.
- Using a 19 mm deep socket wrench, remove the ECT sensor and gasket.

3. INSPECT ECT SENSOR

Using an ohmmeter, measure the resistance between the terminals.

Resistance: Refer to the graph

If the resistance is not as specified, replace the ECT sensor.

4. REINSTALL ECT SENSOR

- Install a new gasket to the ECT sensor.
- Using a 19 mm deep socket, install the ECT sensor.

Torque: 20 N·m (200 kgf·cm, 14 ft·lbf)

- Connect the ECT sensor connector.

5. REFILL WITH ENGINE COOLANT

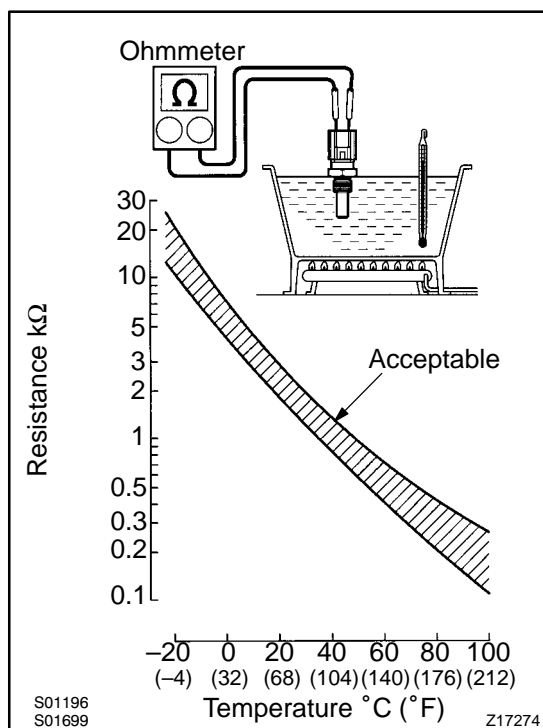

VAPOR PRESSURE SENSOR COMPONENTS

SF101-02

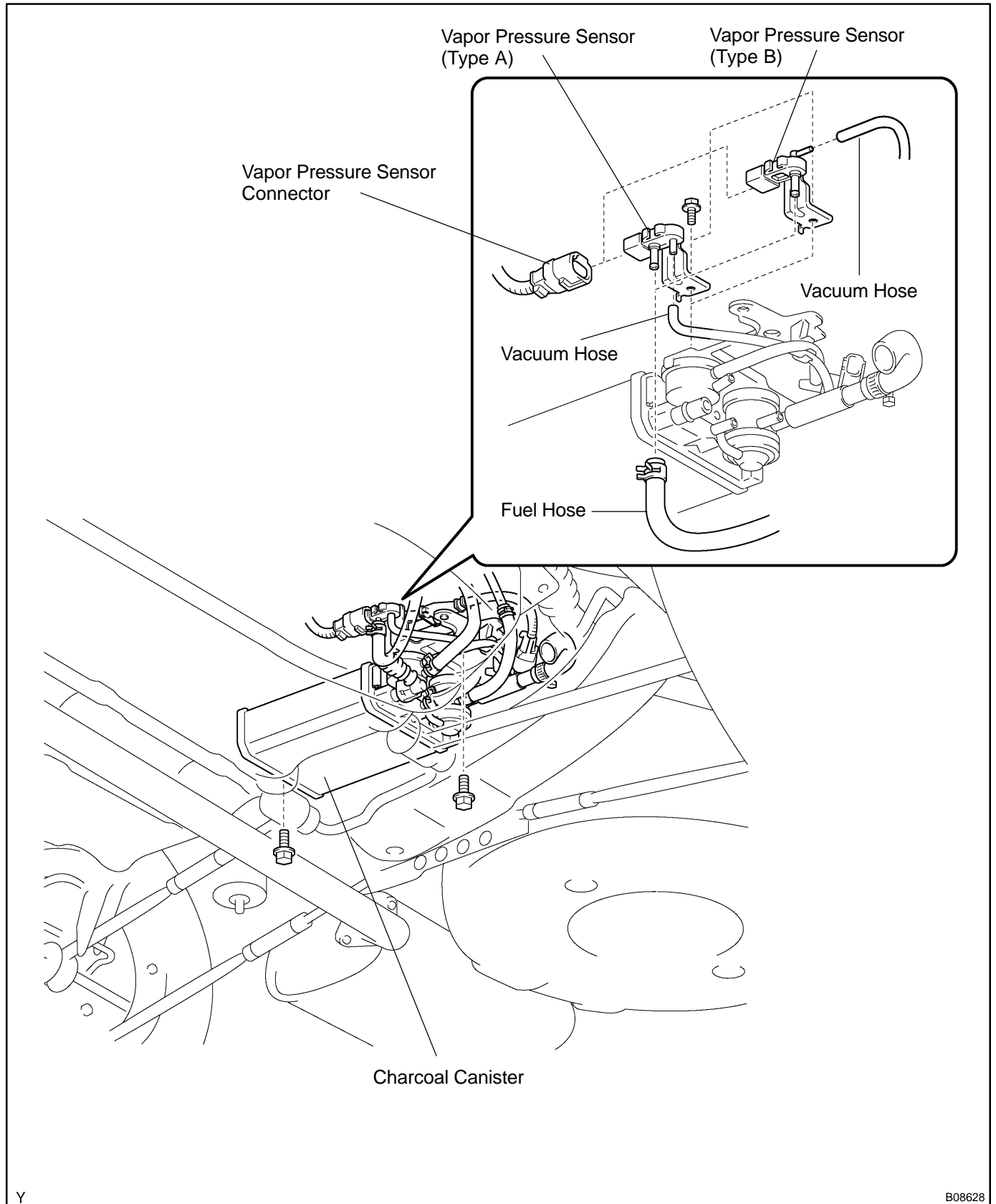

Y

B08628

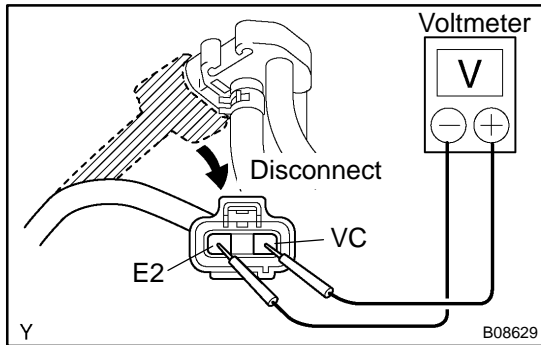

INSPECTION

1. INSPECT POWER SOURCE VOLTAGE OF VAPOR PRESSURE SENSOR

- Disconnect the vapor pressure sensor connector.
- Turn the ignition switch ON.
- Using a voltmeter, measure the voltage between connector terminals VC and E2 of the wiring harness side.
Voltage: 4.5 – 5.5 V
- Turn the ignition switch OFF.
- Reconnect the vapor pressure sensor connector.

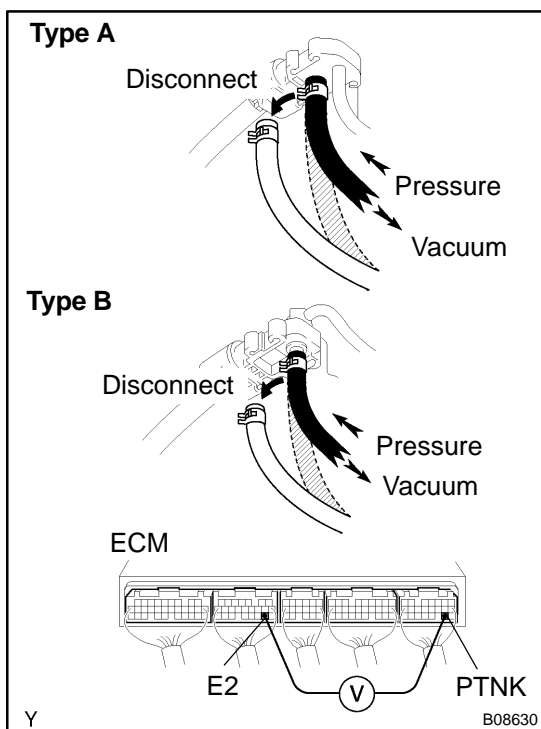

2. INSPECT POWER OUTPUT OF VAPOR PRESSURE SENSOR

- Turn the ignition switch ON.
- Disconnect the fuel hose from the vapor pressure sensor.
- Connect a voltmeter to terminals PTNK and E2 of the ECM, and measure the output voltage under the following conditions:
 - Apply vacuum (2.0 kPa (15 mmHg, 0.59 in.Hg)) to the vapor pressure sensor.
Voltage: 1.3 – 2.1 V
 - Release the vacuum from the vapor pressure sensor.
Voltage: 3.0 – 3.6 V
 - Apply pressure (1.5 kPa (15 gf/cm², 0.22 psi)) to the vapor pressure sensor.
Voltage: 4.2 – 4.8 V
- Turn the ignition switch OFF.
- Reconnect the fuel hose to the vapor pressure sensor.

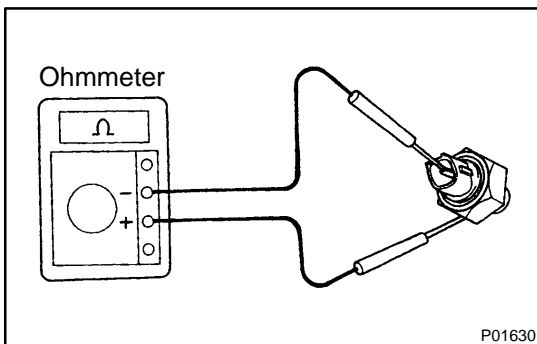
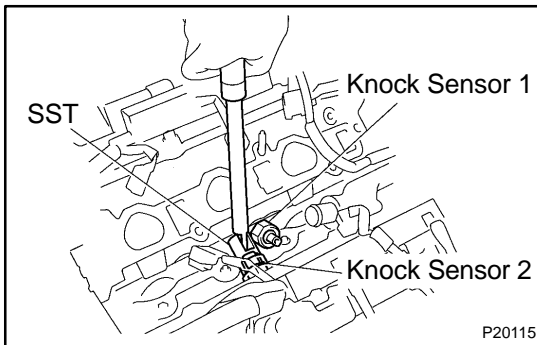
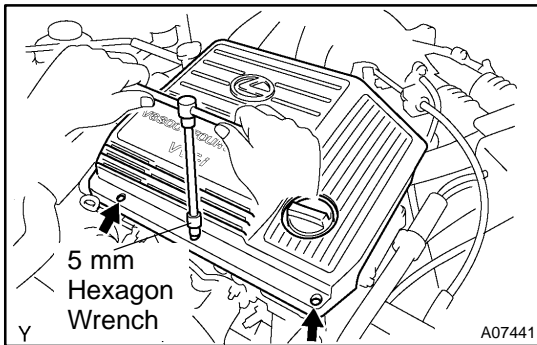

INSPECTION

1. REMOVE V-BANK COVER

- (a) Using a 5 mm hexagon wrench, remove the 3 cap nuts.
- (b) Loosen the V-bank cover fastener counterclockwise.
- (c) Remove the V-bank cover.

2. REMOVE AIR CLEANER HOSE WITH RESONATOR

3. REMOVE INTAKE MANIFOLD ASSEMBLY AND WATER OUTLET (See page [EM-31](#))

4. REMOVE KNOCK SENSORS

- (a) Disconnect the knock sensor connector.
- (b) Using SST, remove the knock sensor.
SST 09817-16011

5. INSPECT KNOCK SENSORS

Using an ohmmeter, check that there is no continuity between the terminal and body.

If there is continuity, replace the sensor.

6. REINSTALL KNOCK SENSORS

- (a) Using SST, install the knock sensor.
SST 09817-16011

Torque: 39 N·m (400 kgf·cm, 29 ft·lbf)

- (b) Connect the knock sensor connector.

7. REINSTALL WATER OUTLET AND INTAKE MANIFOLD ASSEMBLY (See page [EM-59](#))

8. REINSTALL AIR CLEANER HOSE WITH RESONATOR

9. REINSTALL V-BANK COVER

- (a) Using 5 mm hexagon wrench, install the V-bank cover with the 3 cap nuts.
- (b) Press down the V-bank cover fastener.

AIR-FUEL RATIO (A/F) SENSOR COMPONENTS

SF103-01

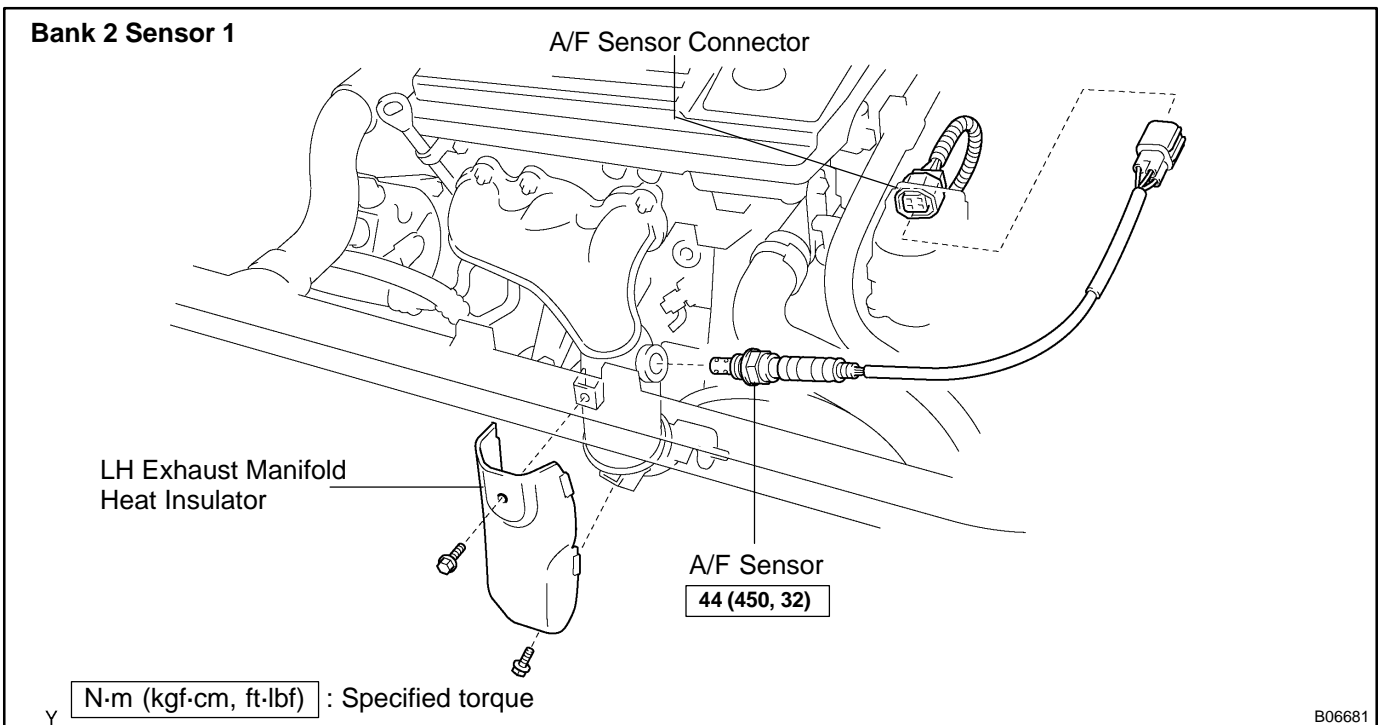
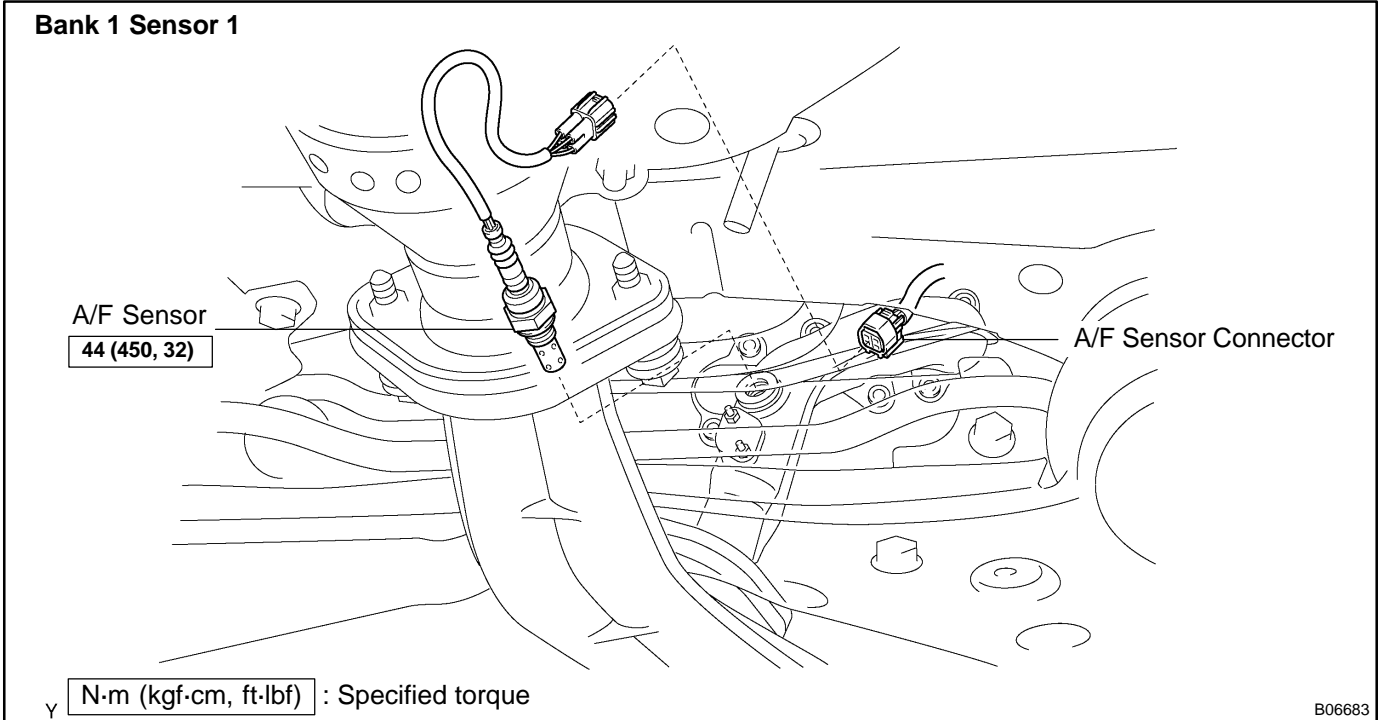

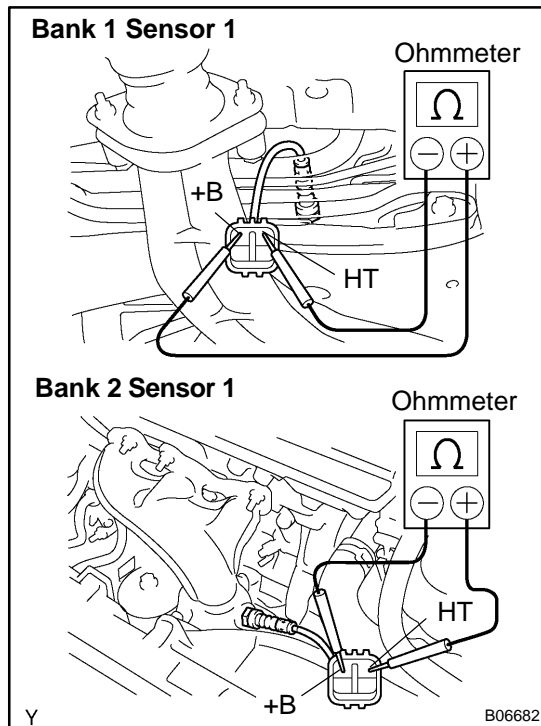

INSPECTION

INSPECT HEATER RESISTANCE OF A/F SENSORS

(Bank 1 sensor 1, Bank 2 Sensor 1)

- Disconnect the A/F sensor connector.
- Using an ohmmeter measure the resistance between terminals +B and HT.

Resistance:

At 20°C (68°F)	0.8 – 1.4 Ω
At 800°C (1,472°F)	1.8 – 3.2 Ω

If the resistance is not as specified, replace the sensor.

Torque: 44 N·m (450 kgf·cm, 32 ft·lbf)

- Reconnect the A/F sensor connector.

HEATED OXYGEN SENSOR COMPONENTS

SF105-01

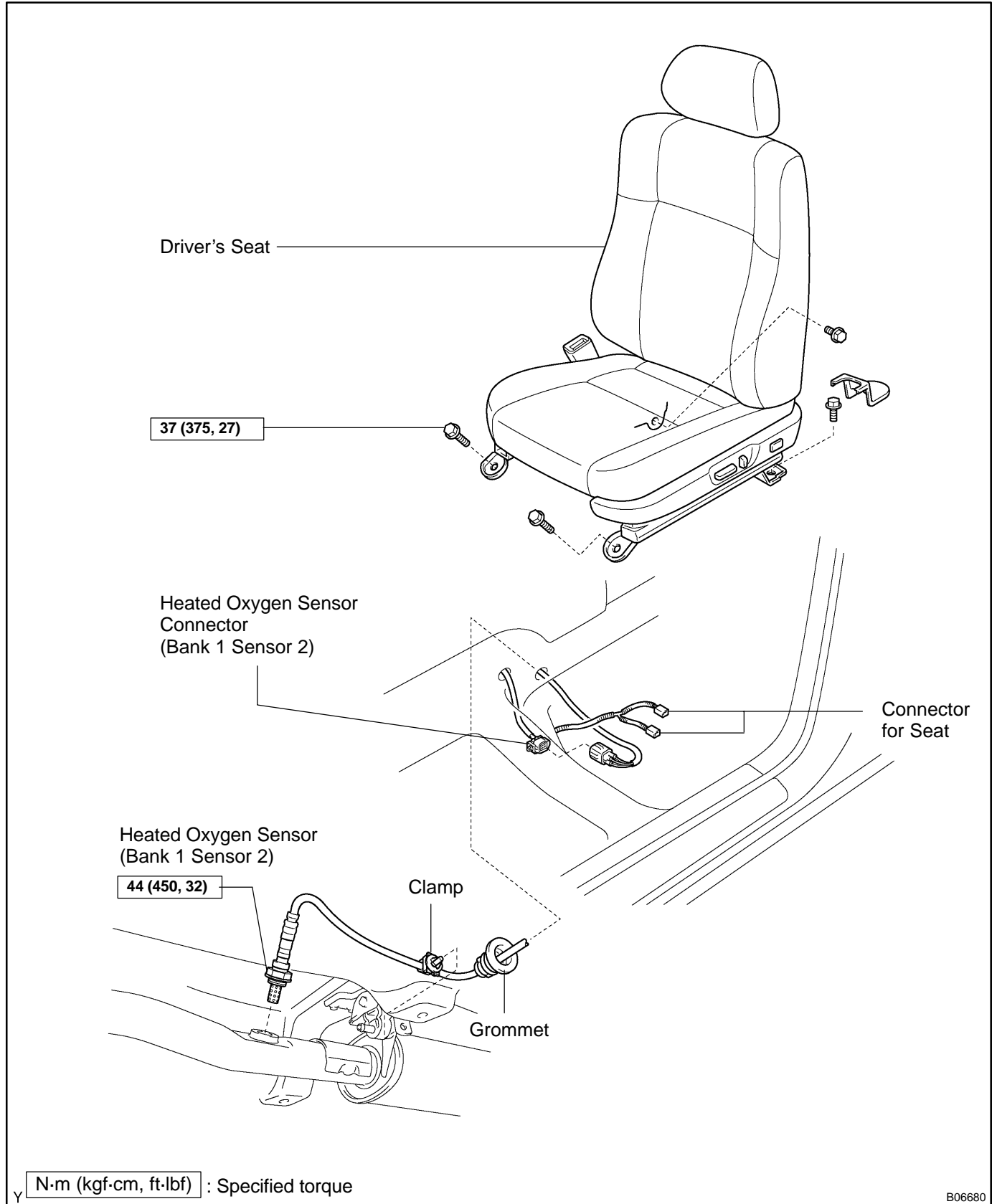

ENGINE CONTROL MODULE (ECM) COMPONENTS

SF06Z-03

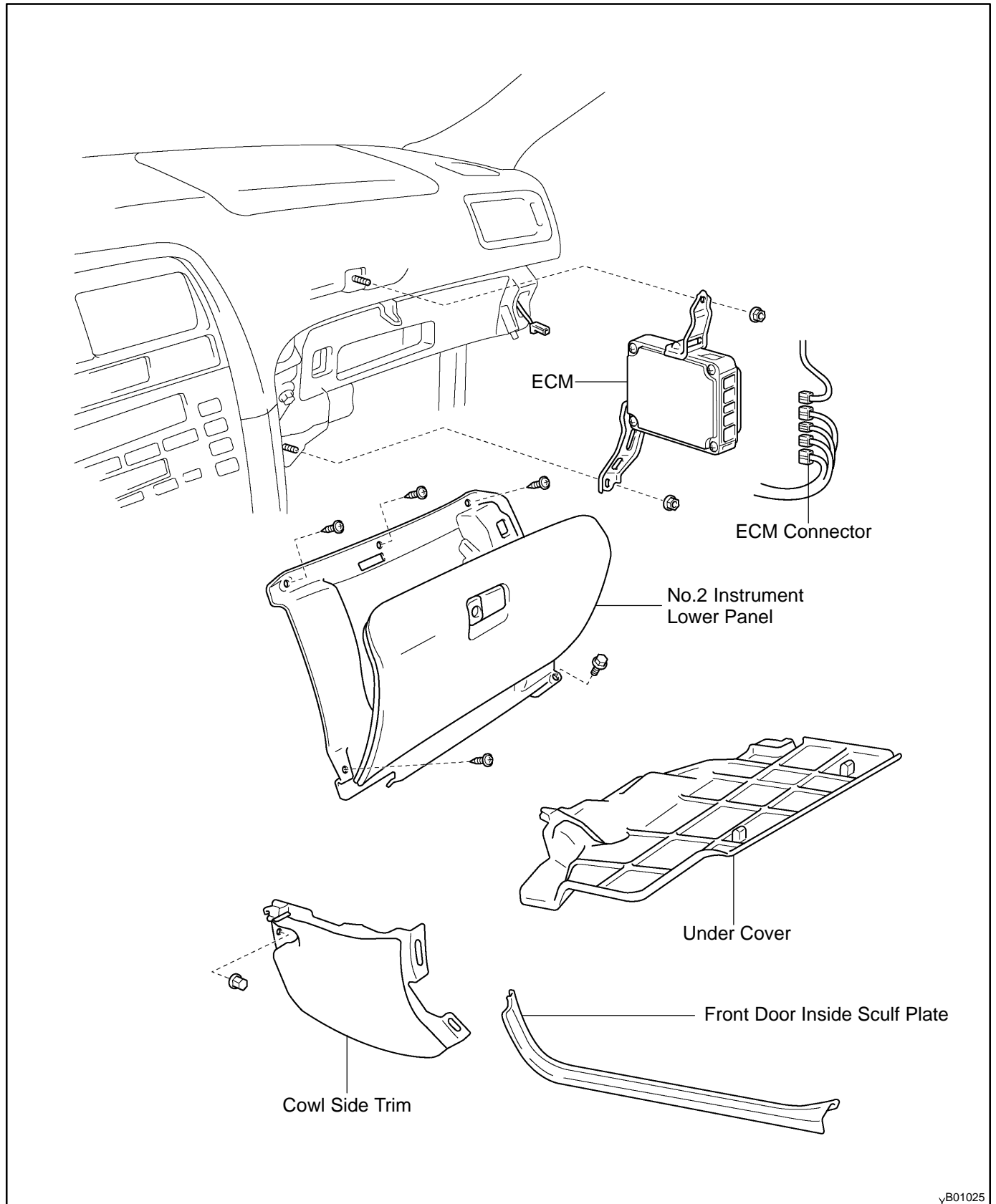

√B01025

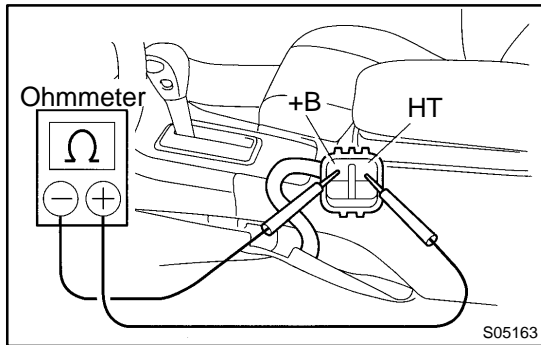

INSPECTION

INSPECT HEATER RESISTANCE OF HEATED OXYGEN SENSOR (Bank 1 Sensor 2)

- Remove the driver's seat.
- Disconnect the oxygen sensor connector.
- Using an ohmmeter, measure the resistance between the terminals +B and HT.

Resistance:

At 20°C (68°F)	11 – 16 Ω
At 800°C (1,472°F)	23 – 32 Ω

If the resistance is not as specified, replace the sensor.

Torque: 44 N·m (450 kgf·cm, 32 ft·lbf)

- Reconnect the oxygen sensor connector.
- Reinstall the driver's seat.

INSPECTION

1. REMOVE ECM
2. INSPECT ECM (See page [DI-20](#))
3. REINSTALL ECM

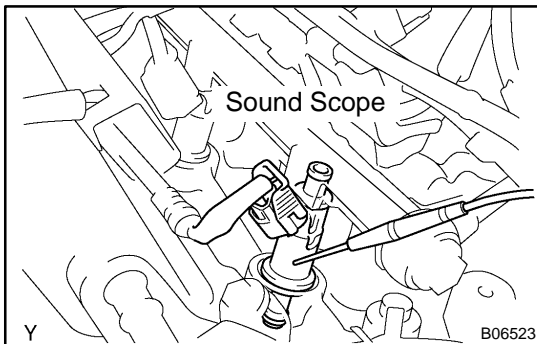
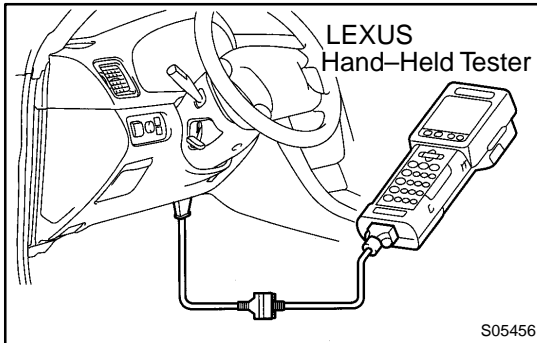
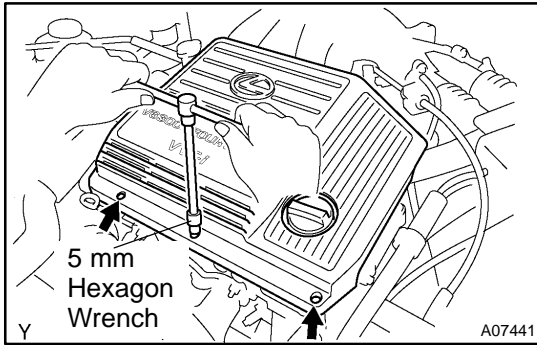

FUEL CUT RPM INSPECTION

SF071-03

1. REMOVE V-BANK COVER

- Using a 5 mm hexagon wrench, remove the 3 cap nuts.
- Loosen the V-bank cover fastener counterclockwise.
- Remove the V-bank cover.

2. WARM UP ENGINE

Allow the engine to warm up to normal operating temperature.

3. CONNECT LEXUS HAND-HELD TESTER OR OBDII SCAN TOOL

- Connect the LEXUS hand-held tester or OBDII scan tool to the DLC3.
- Please refer to the LEXUS hand-held tester or OBDII scan tool operator's manual for further details.

4. INSPECT FUEL CUT OFF PRM

- Increase the engine speed to at least 3,500 rpm.
- Use a sound scope to check for injector operating noise.
- Check that when the throttle lever is released, injector operation noise stops momentarily and then resumes.

HINT:

Measure with the A/C OFF.

Fuel return rpm: 1,200 rpm

5. DISCONNECT LEXUS HAND-HELD TESTER OR OBDII SCAN TOOL

6. REINSTALL V-BANK COVER

- Using 5 mm hexagon wrench, install the V-bank cover with the 3 cap nuts.
- Press down the V-bank cover fastener.